

CHAPTER 9

ELECTRICAL SYSTEM

<u>1</u>	<u>Electrical System</u>	<u>9-1</u>
<u>2</u>	<u>Battery</u>	<u>9-6</u>
<u>3</u>	<u>Starter Motor</u>	<u>9-9</u>
<u>4</u>	<u>Alternator 12V/55A</u>	<u>9-20</u>
<u>5</u>	<u>Instrument Panel and Wiring Codes</u>	<u>9-30</u>
<u>6</u>	<u>Warning Devices</u>	<u>9-35</u>
<u>7</u>	<u>Air Heater (Optional)</u>	<u>9-38</u>
<u>8</u>	<u>Electric Type Engine Stop Device (Optional)</u>	<u>9-39</u>
<u>9</u>	<u>Tachometer)</u>	<u>9-41</u>
<u>10</u>	<u>Alternator 12V/80A (Optional)</u>	<u>9-44</u>

1. Electrical System

1-1 System diagrams of electric parts

1-1.1 B-type instrument panel

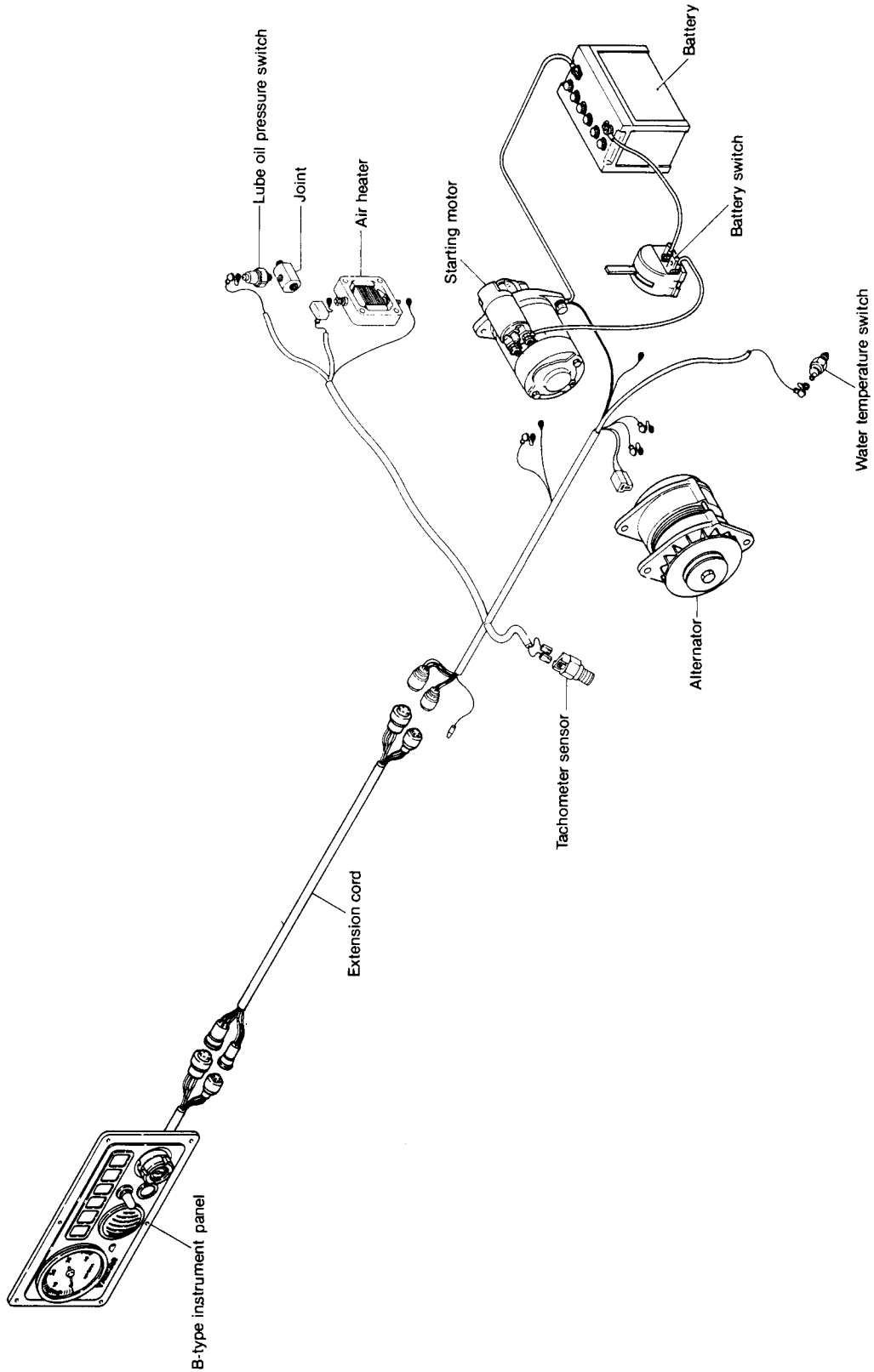

1-1.2 C-type and D-type instrument panel

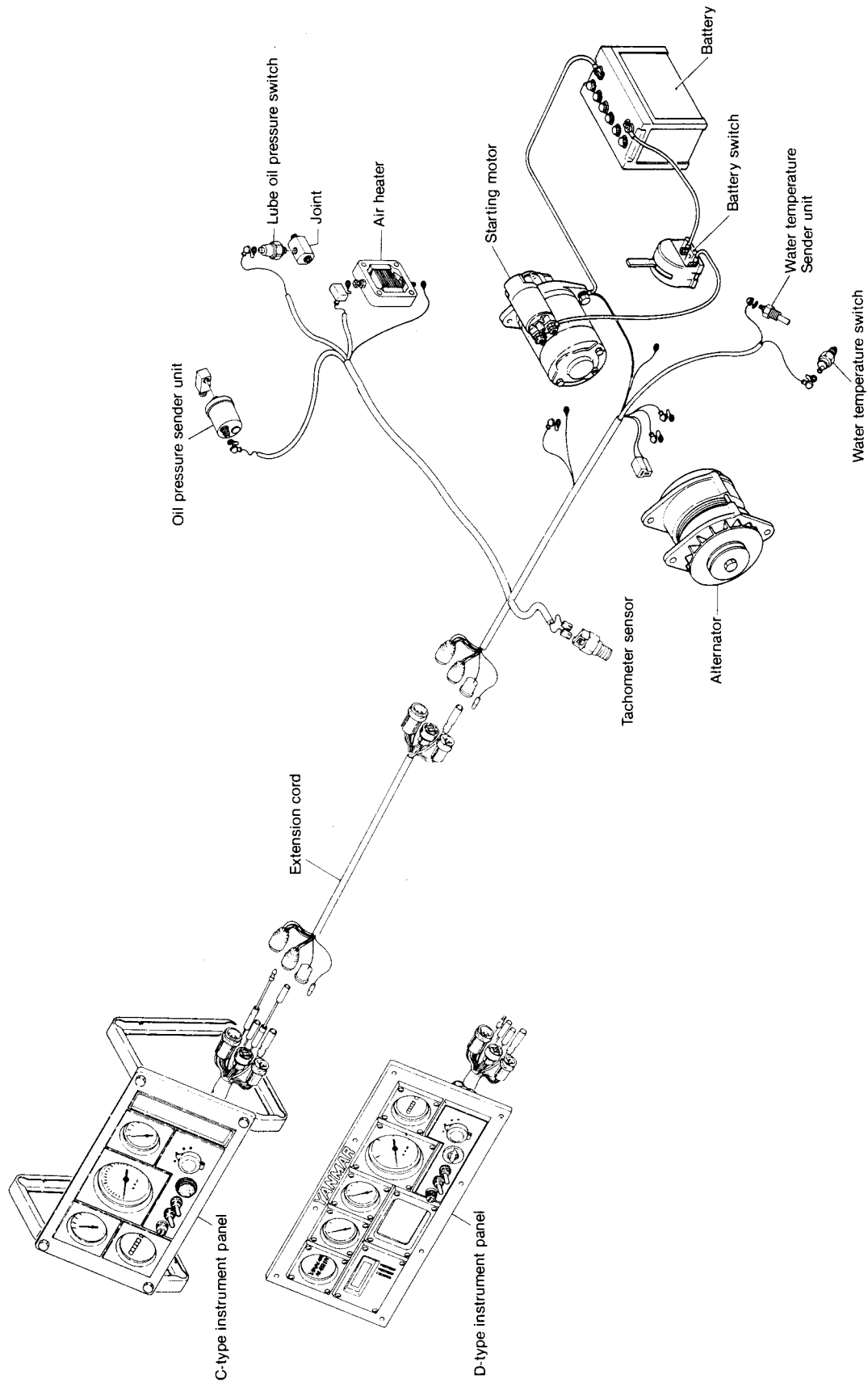

1-2 Wiring diagram

1-2.1 For B-type instrument panel

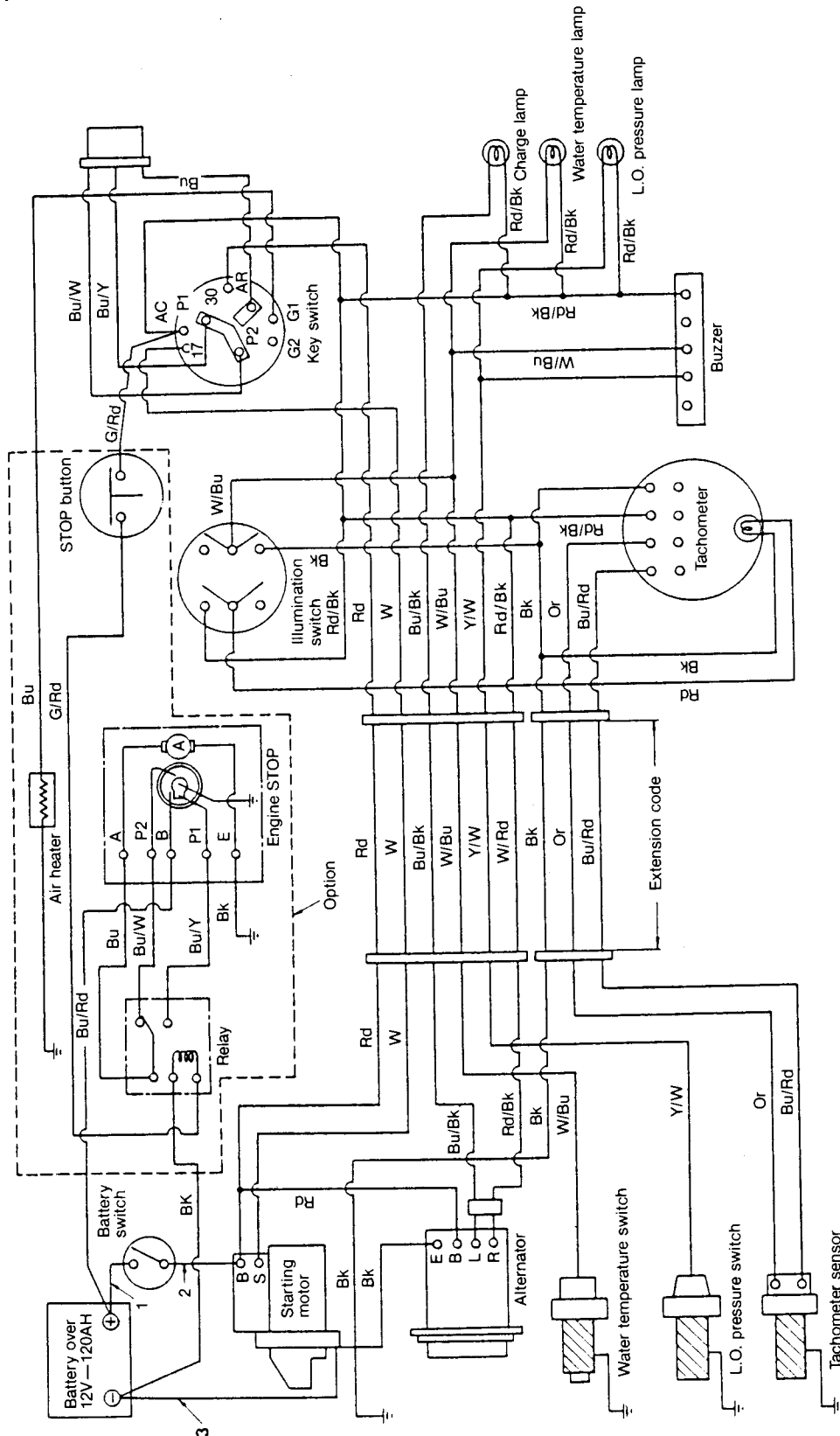

1-2.3 For D-type instrument panel

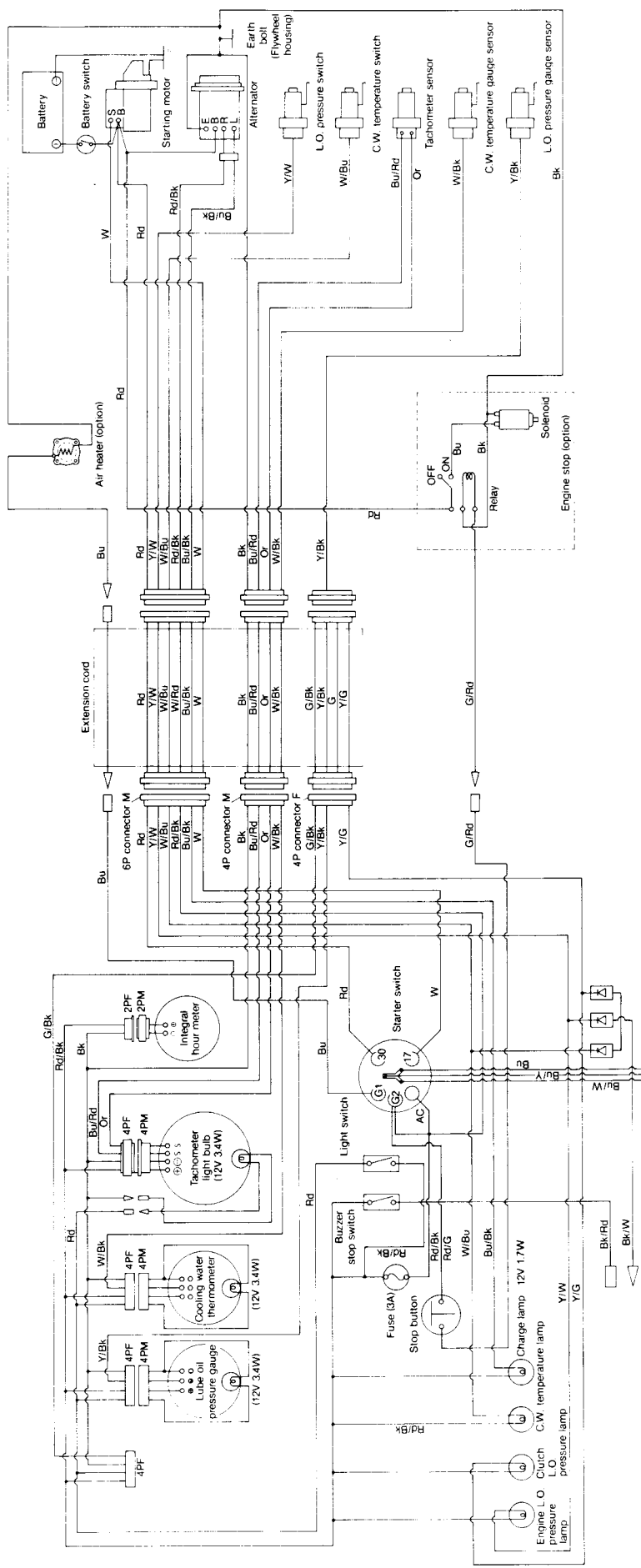

Color-coding

Rd:	Red
W:	White
Bk:	Black
Bu:	Blue
Y:	Yellow
Or:	Orange
G:	Green

2. Battery

2-1 Construction

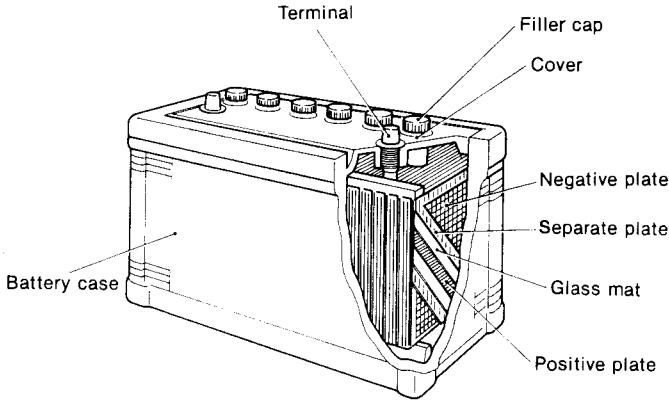

The battery utilizes chemical action to convert chemical energy to electrical energy. This engine uses a lead acid battery which stores a fixed amount of power that can be used when required. After use, the battery can be recharged and used again.

As shown in the figure, a nonconductive container is filled with dilute sulfuric acid electrolyte. Lead dioxide positive plates and lead dioxide negative plates separated by glass mats are stacked alternately in the electrolyte. The positive and negative plates are connected to their respective terminals.

Power is removed from the battery by connecting the load across these two terminals.

When the battery is discharging, an electric current flows from the positive plates to the negative plates. When the battery is being charged, electric current is passed through the battery in the opposite direction by an external power source.

2-2 Battery capacity and battery cables

2-2.1 Battery capacity

Since the battery has a minimum capacity of 12V, 70AH, it can be used for 100 ~ 150AH.

Battery capacity	minimum	12V — 100AH
	standard	12V — 120AH
	cold weather	12V — 150AH
Full charged specific gravity		1.26

2-2.2 Battery cable

Wiring must be performed with the specified electric wire. Thick, short wiring should be used to connect the battery to the starter, (soft automotive low-voltage wire [AV wire]). Using wire other than that specified may cause the following troubles:

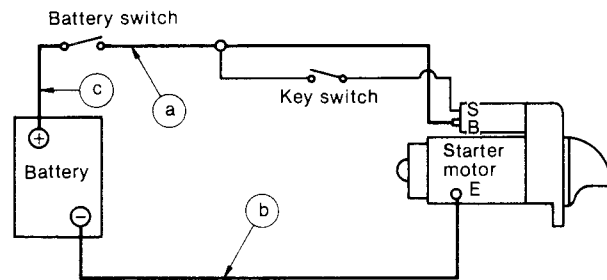
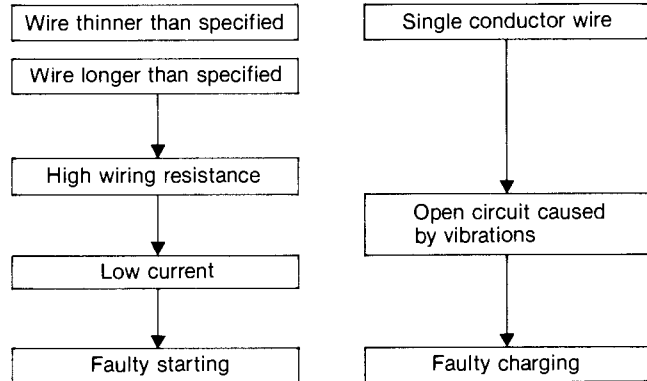

The overall lengths of the wire between the battery (+) terminal and the starter (B) terminal, and between the battery (-) terminal and the starter (E) terminal, should be determined according to the following table.

Voltage system	Allowable wiring voltage drop	Conductor cross-section area	a + b + c allowable length
12V	0.2V or less/100A	20mm ² (0.0311 in. ²)	Up to 2.5m (98.43 in.)
		40mm ² (0.062 in. ²)	Up to 5m (196.87 in.)

Note: Excessive resistance in the key switch circuit (between the battery and start [S] terminals) can cause improper pinion engagement. To prevent this, follow the wiring diagram carefully.

2-3 Inspection

The quality of the battery governs the starting performance of the engine. Therefore the battery must be routinely inspected to ensure that it functions perfectly at all times.

2-3.1 Visual inspection

- (1) Inspect the case for cracks, damage and electrolyte leakage.
- (2) Inspect the battery holder for tightness, corrosion, and damage.
- (3) Inspect the terminals for rusting and corrosion, and check the cables for damage.
- (4) Inspect the caps for cracking, electrolyte leakage and clogged vent holes.

Correct any abnormal conditions found. Clean off rusted terminals with a wire brush before reconnecting the battery cable.

2-3.2 Checking the electrolyte

(1) Electrolyte level

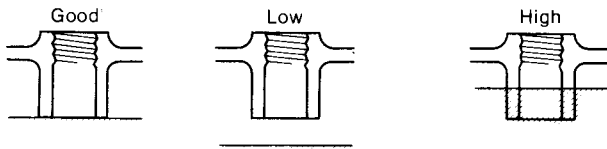

Check the electrolyte level every 7 to 10 days. The electrolyte must always be 10 ~ 20mm (0.3937 ~ 0.7874in.) over the top of the plates.

- NOTES: 1. The "LEVEL" line on a transparent plastic battery case indicates the height of the electrolyte.
 2. Always use distilled water to bring up the electrolyte level.
 3. When the electrolyte has leaked out, add dilute sulfuric acid with the same specific gravity as the electrolyte.

(2) Measuring the specific gravity of the electrolyte

- 1) Draw some of the electrolyte up into a hydrometer.

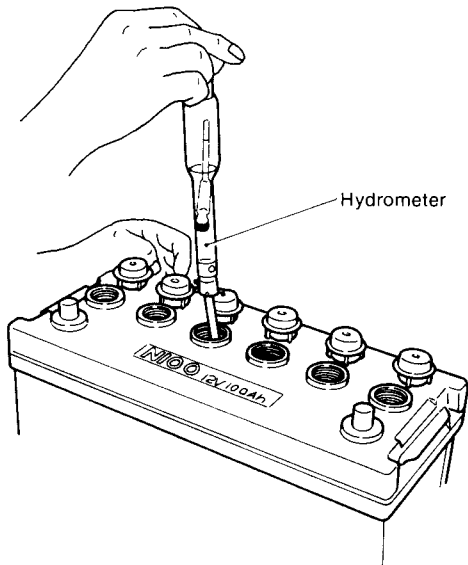

- 2) Take the specific gravity reading at the top of the scale of the hydrometer.

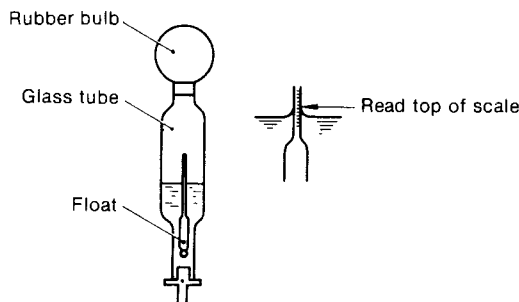

- 3) The battery is fully charged if the specific gravity is 1.260 at an electrolyte temperature of 20°C. The battery is discharged if the specific gravity is 1.200

(50%). If the specific gravity is below 1.200, recharge the battery.

- 4) If the difference in the specific gravity among the cells of the battery is ± 0.01 , the battery is OK.
 5) Measure the temperature of the electrolyte. Since the specific gravity changes with the temperature, 20°C is used as the reference temperature.

Reading the specific gravity at 20°C

$$S_{20} = S_t + 0.0007(t - 20)$$

S_{20} : Specific gravity at the standard temperature of 20°C

S_t : Specific gravity of the electrolyte at t°C

0.0007: Specific gravity change per 1°C

t: Temperature of electrolyte

2-3.3 Voltage test

Using a battery tester, the amount of discharge can be determined by measuring the voltage drop which occurs while the battery is being discharged with a large current.

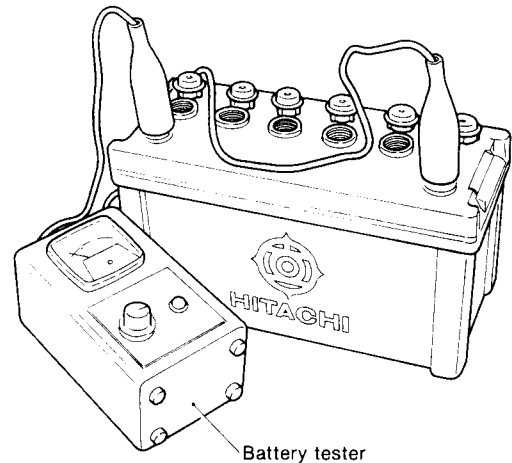

- (1) Connect the tester to the battery.
 12V battery tester
 Adjust the current (A).
 (2) Connect the (+) lead of the tester to the (+) battery terminal, and the (-) tester lead to the (-) battery terminal.
 (3) Push the TEST button, wait 5 seconds, and then read the meter.
 • Repeat the test twice to make sure that the meter indication remains the same.

2-3.4 Washing the battery

- (1) Wash the outside of the battery with a brush while running cold or warm water over the battery. (Make sure that no water gets into the battery.)
 (2) When the terminals or other metal parts are corroded due to exposure to electrolyte leakage, wash off all the acid.
 (3) Check the vent holes of the caps and clean if clogged.
 (4) After washing the battery, dry it with compressed air, connect the battery cable, and coat the terminals with grease. Since the grease acts as an insulator, do not coat the terminals before connecting the cables.

2-4 Charging

2-4.1 Charging methods

There are two methods of charging a battery: normal and rapid.

Rapid charging should only be used in emergencies.

- Normal charging... Should be conducted at a current of 1/10 or less of the indicated battery capacity (10A or less for a 100AH battery).
- Rapid charging... Rapid charging is done over a short period of time at a current of 1/5 ~ 1/2 the indicated battery capacity (20A ~ 50A for a 100AH battery). However, since rapid charging causes the electrolyte temperature to rise too high, special care must be exercised.

2-4.2 Charging procedure

- (1) Check the specific gravity and adjust the electrolyte level.
- (2) Disconnect the battery cables.
- (3) Connect the red clip of the charger to the (+) battery terminal and connect the black clip to the (-) terminal.

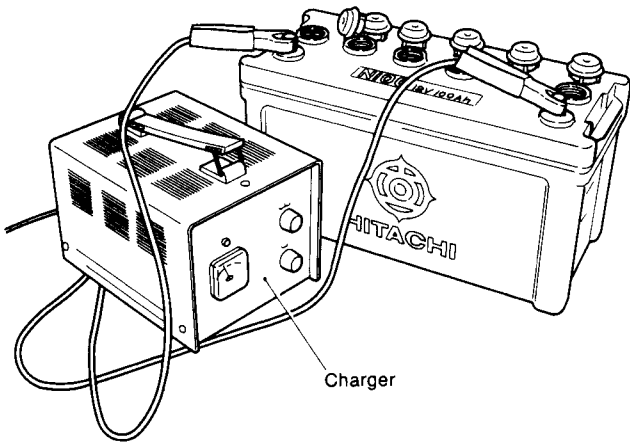

- (4) Set the current to 1/10 ~ 1/5 of the capacity indicated on the outside of the battery.
- (5) Periodically measure the specific gravity during charging to make sure that the specific gravity remains at a high fixed value. Also check whether gas is being generated.

2-4.3 Charging precautions

- (1) Remove the battery caps to vent the gas during charging.
- (2) While charging, ventilate the room and prohibit smoking, welding, etc.
- (3) The electrolyte temperature should not exceed 45°C during charging.
- (4) Since an alternator is used on this engine, when charging with a charger, always disconnect the battery (+) cable to prevent destruction of the diodes. (Before disconnecting the (+) battery cable, disconnect the (-) battery cable [ground side].)

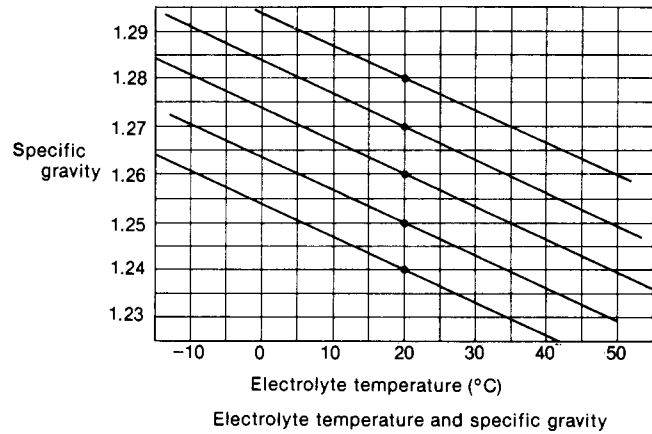

2-5 Battery storage precautions

The life of a battery depends considerably on how it is handled. Generally speaking, however, after about two years its performance will deteriorate, starting will become difficult, and the battery will not fully recover its original charge even after recharging. Then it must be replaced.

- (1) Since the battery will self-discharge about 0.5%/day even when not in use, it must be charged 1 or 2 times a month when it is being stored.

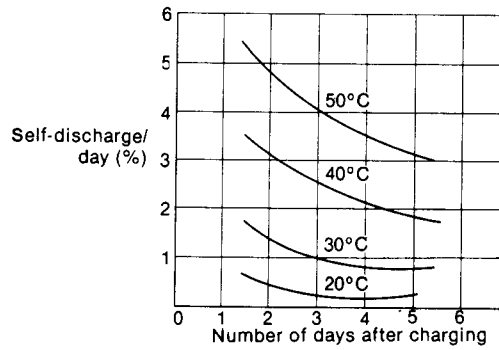

- (2) If charging by the engine alternator is insufficient because of frequent starts and stops, the battery will rapidly lose power.

Charge the battery as soon as possible after it is used under these conditions.

- (3) An easy-to-use battery charger that permits home charging is available from Yanmar. Take proper care of the battery by using the charger as a set with a hydrometer.

When the specific gravity has dropped to about 1.16 and the engine will not start, charge the battery up to a specific gravity of 1.26 (24 hours).

- (4) Before putting the battery in storage for long periods, charge it for about 8 hours to prevent rapid aging.

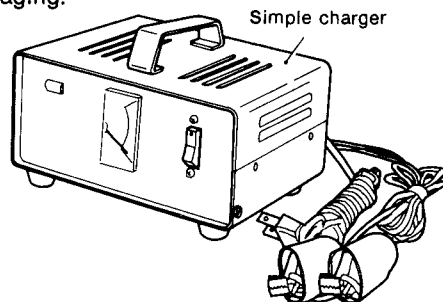

3. Starter Motor

The starter motor is installed on the flywheel housing. When the starting button is pushed, the starter motor pinion flies out and engages the ring gear of the flywheel. Then the main contact is closed, current flows, and the engine is started.

After the engine starts, the pinion automatically returns to its initial position when the starting button is released. Once the engine starts, the starting button should be released immediately. Otherwise, the starter motor may be damaged or burned out.

3-1 Specifications and Performance.

Engine model	4JHE, 4JH-TE 4JH-HTE, 4JH-DT(B)E	
Model	S12-77A	
Rating (sec.)	30	
Output (kW)	1.8	
Direction of rotation (viewed from pinion side)	Clockwise	
Weight kg (lb.)	9.3 (20.5)	
Clutch system	Overrunning	
Engagement system	Magnetic shift	
No. of pinion teeth	15	
Pinion flyout voltage (V)	8 or less	
No-load	Terminal voltage (V)	12
	Current (A)	90 or less
	Speed (rpm)	4000 or greater
Loaded characteristics	Terminal voltage (V)	8.5
	Current (A)	420
	Torque kg-m (ft.-lb.)	1.35 (9.76) or greater

3-2 Construction

The starter motor described in this section is a conventional pre-engaged 4-brush 4-pole starter motor with a screw roller drive clutch.

The starter motor is composed of three major parts, as follows:

- (1) Magnetic switch
Moves plunger to engage and disengage pinion and, through the engagement lever, opens and closes the main contact (moving contact) to stop the starter motor.
- (2) Motor
A continuous current series motor which generates rotational drive power.
- (3) Pinion
Transfers driving power from motor to ring gear. An over-speed clutch is employed to prevent damage if the engine should run too fast.

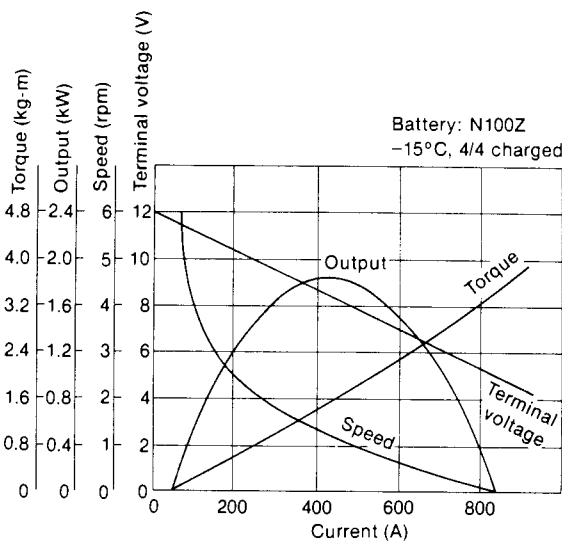

S12-77A Performance curves

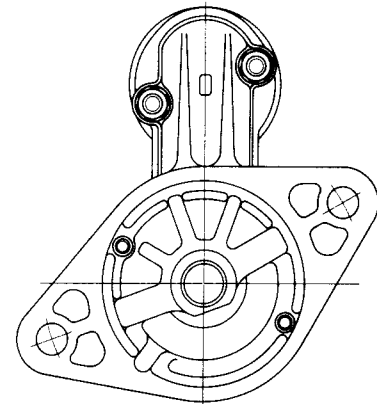
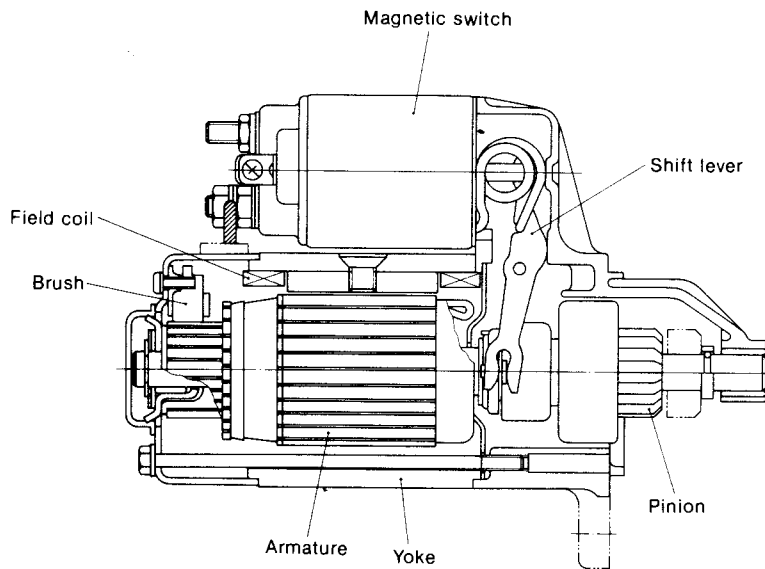
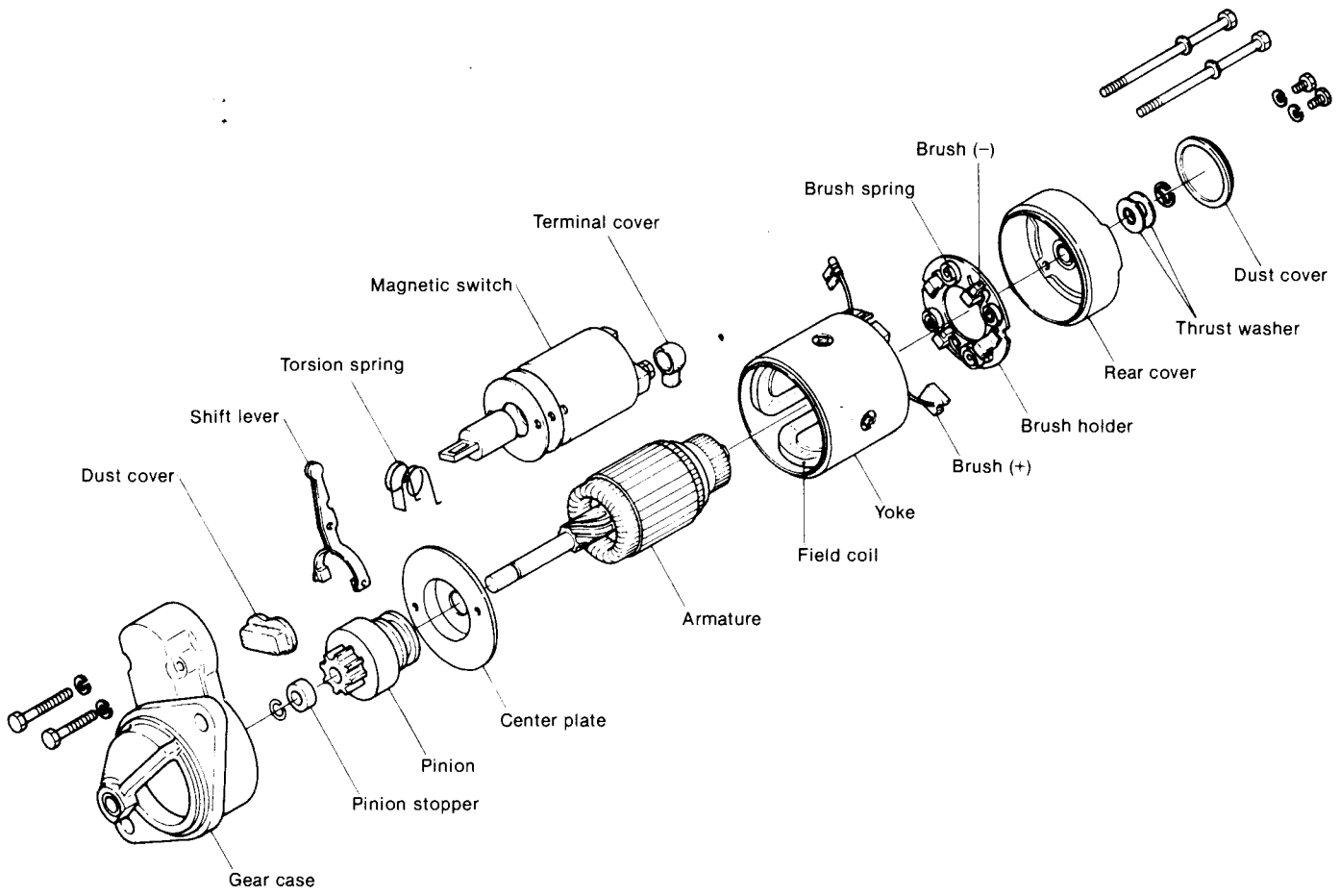

To prevent the motor receiving a shock when the engine starts and over-runs, the starter motor has an over-running clutch.

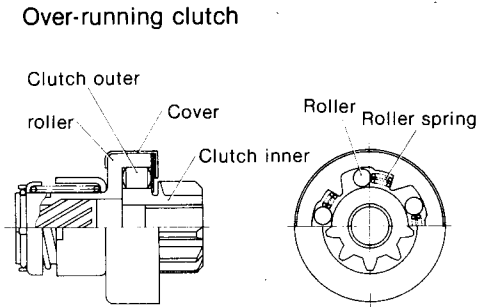

3-3 Operation

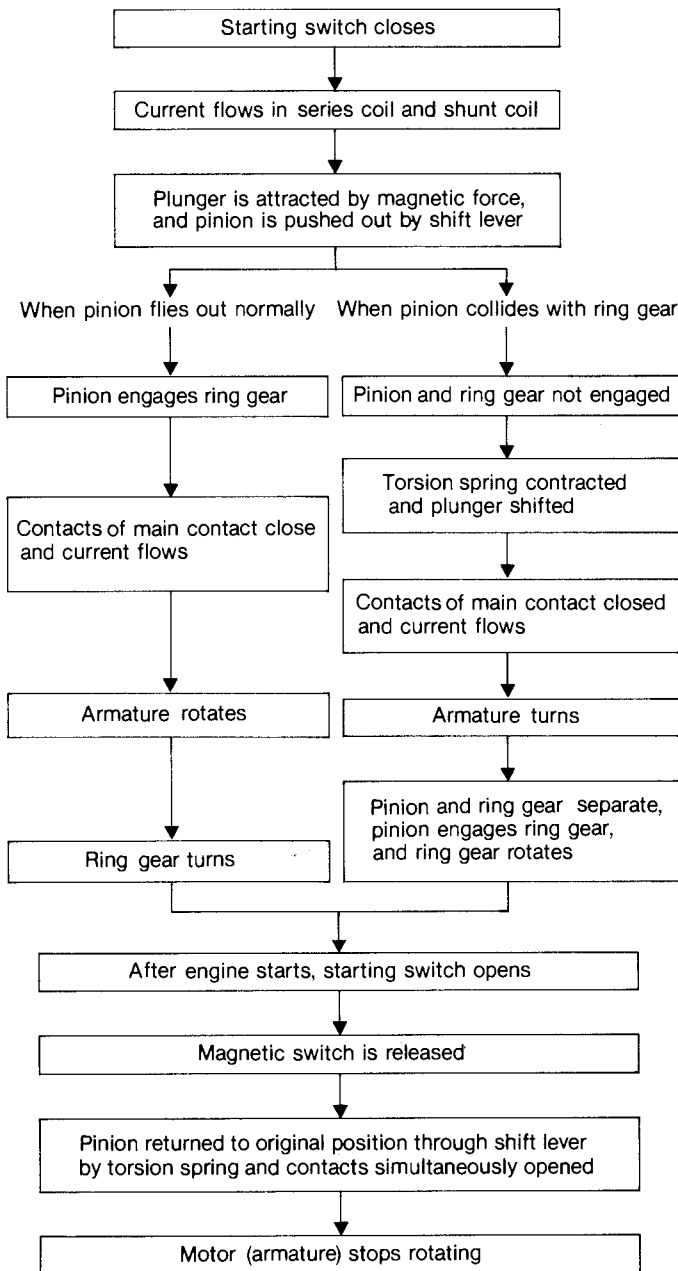

3-4 Adjustment and performance test

3-4.1 L-size measurement (gap between pinion and pinion stopper)

When the pinion is at the projected position, measure gap between pinion and pinion stopper. This check should be made with the pinion pressed back lightly to take up any play in the engagement linkage.

	Starter motor	l dimension mm (in.)
	S12-77A	0.2 ~ 1.5 (0.0079 ~ 0.0591)

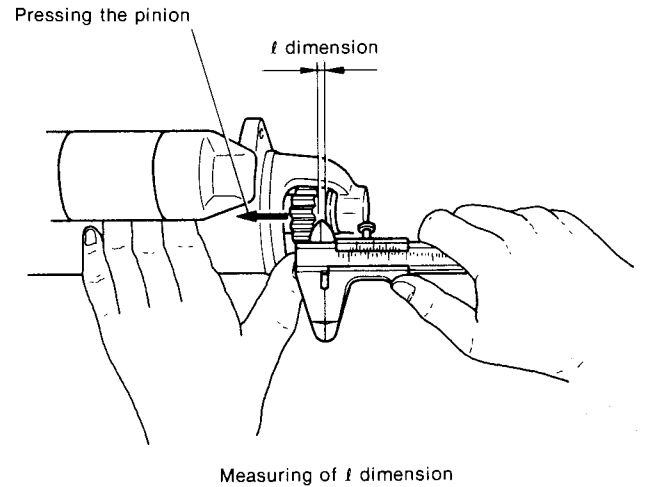

3-4.2 Pinion movement

After complete assembly of the starter motor, connect up the motor as in Fig.

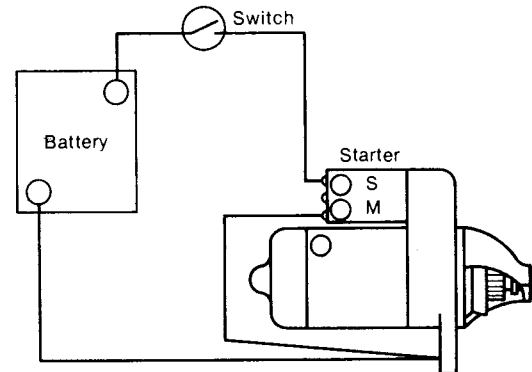

3-4.3 Plunger movement

Adjustment made by adjusting stroke of magnetic plunger to the prescribed value.

Adjust the *l*-dimension by adjusting screw and nut.

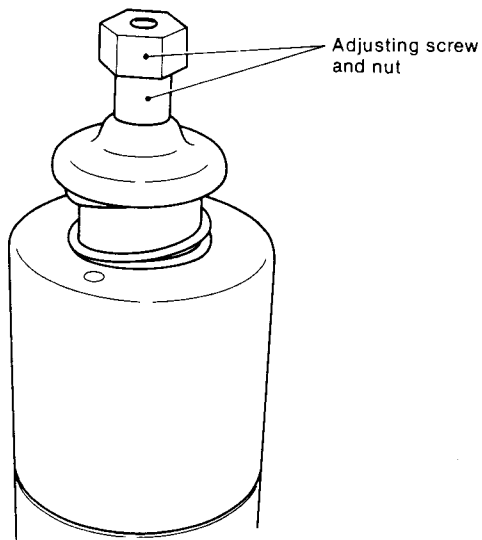

3-5 Disassembly

3-5.1 Magnetic switch

- (1) Disconnect magnetic switch wiring.
- (2) Remove through bolt mounting magnetic switch.
- (3) Remove magnetic switch.

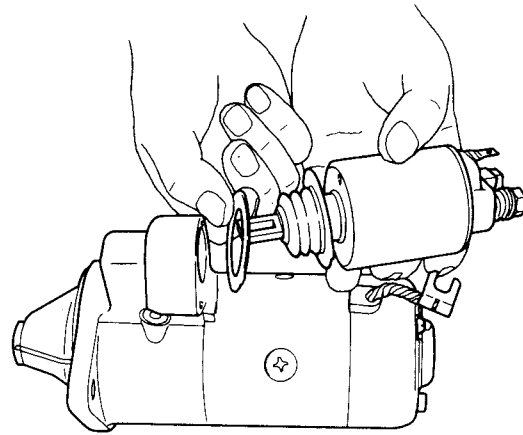

3-5.2 Rear cover

- (1) Remove dust cover.

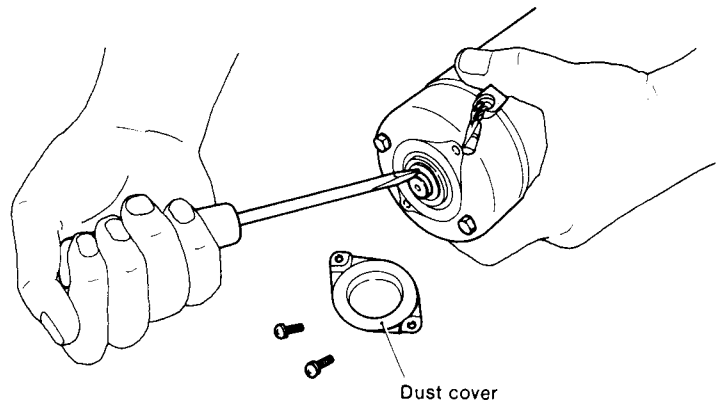

3-4.4 Pinion lock torque measurement

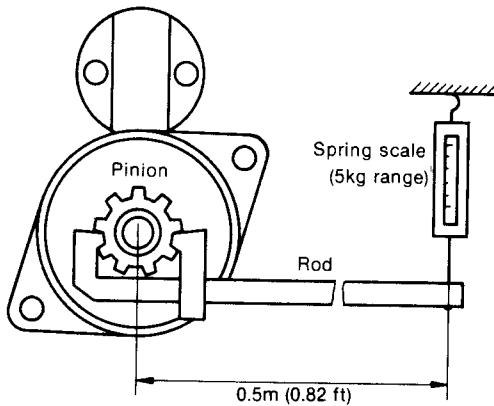

- (2) Remove E-ring, and remove thrust washer (be careful not to lose the washer and shim).
- (3) Remove the two through bolts holding the rear cover and the two screws holding the brush holder.
- (4) Remove rear cover.

3-4.5 Mesh clearance

Mesh clearance is the distance between the flywheel ring gear and starter motor pinion in the rest position. This clearance should be between 3mm (0.1181in.) to 5mm (0.1969in.).

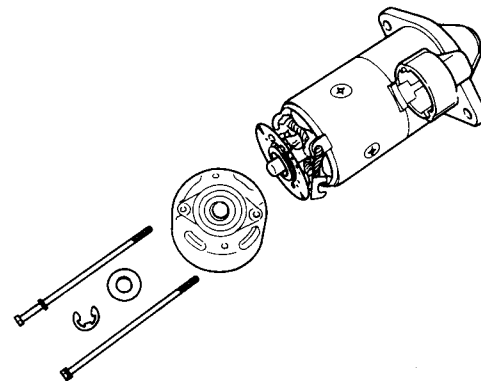
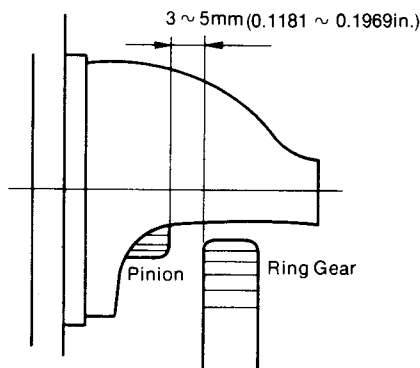

3-5.3 Brush holder

- (1) Float (-)brush from the commutator.
- (2) Remove (+)brush from the brush holder.
- (3) Remove brush holder.

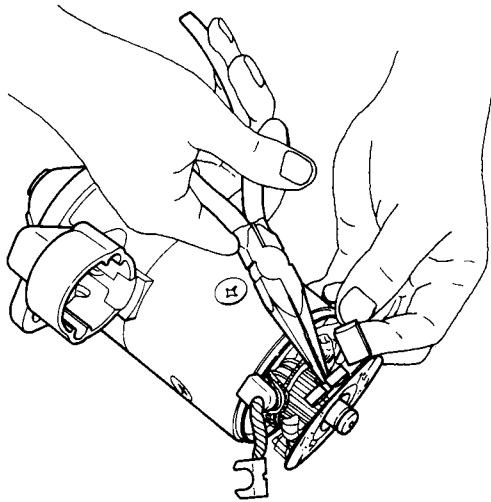

3-5.4 Yoke

- (1) Remove yoke. Pull it out slowly so that it does not strike against other parts.

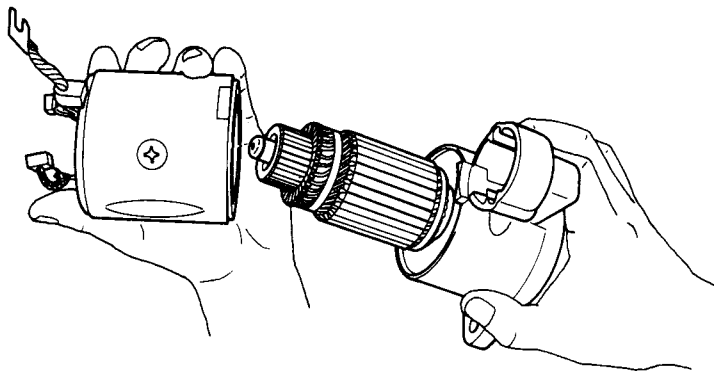

3-5.5 Armature

- (1) Slide pinion stopper to pinion side.

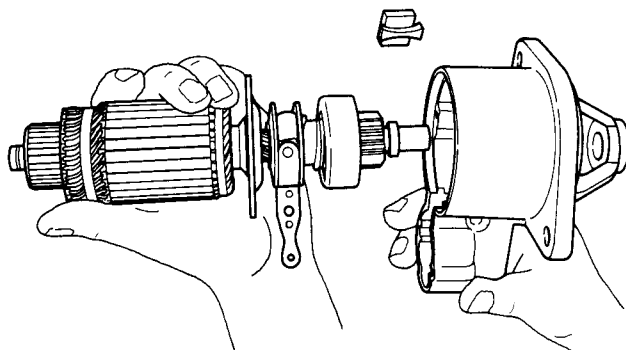

- (2) Remove the pinion stopper clip.

3-5.6 Pinion

- (1) Slide the pinion stopper to the pinion side.
- (2) Remove the pinion stopper clip.
- (3) Remove the pinion from the armature.

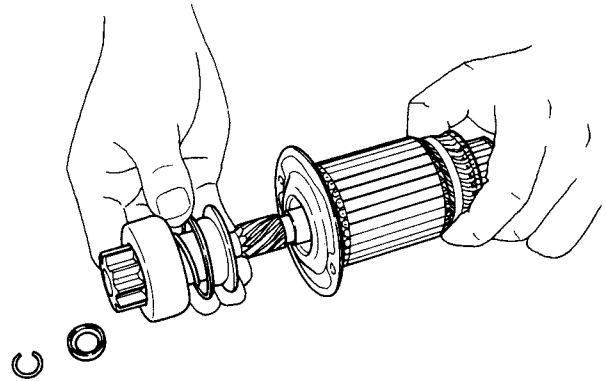

3-6 Inspection

3-6.1 Armature

- (1) Commutator

Inspect the surface of the commutator. If corroded or pitted, sand with #500 ~ #600 sandpaper. If the commutator is severely pitted, grind it to within a surface roughness of at least 0.4 by turning it on a lathe. Replace the commutator if damage is irreparable.

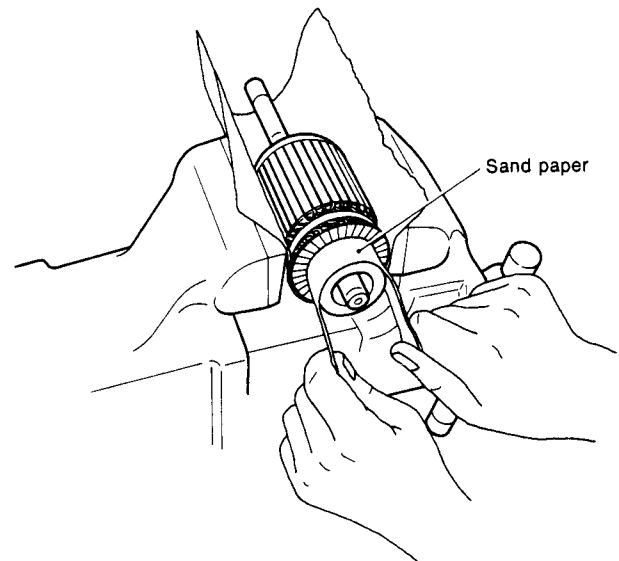

	S12-77A	
	Maintenance standard	Wear limit
Commutator outside diameter	ø43 (1.693)	ø40 (1.575)
Commutator run-out	Within 0.03 (0.0012)	0.2 (0.0079)
Difference between maximum diameter and minimum diameter	Repair limit 0.4 (0.0157)	Repair accuracy 0.05 (0.002)

(2) Mica undercut

Check the mica undercut, correct with a hacksaw blade when the undercut is too shallow.

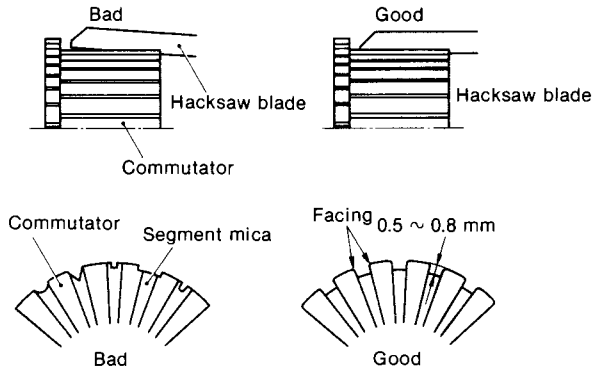

mm (in.)

	Maintenance standard	Repair limit
Mica undercut	0.2 (0.0079)	0.5 ~ 0.8 (0.0197 ~ 0.0315)

(3) Armature coil ground test

Using a tester, check for continuity between the commutator and the shaft (or armature core). Continuity indicates that these points are grounded and that the armature must be replaced.

- 1) Short test...existence of broken or disconnected coil.
- 2) Insulation test...between commutator and armature core or distortion shaft.

Checking commutator for insulation defects.

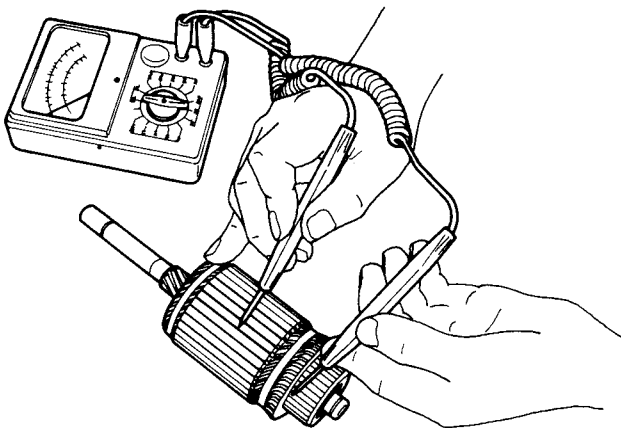

Checking armature windings for insulation faults.

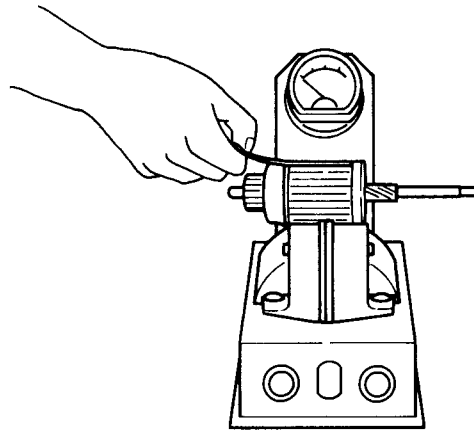

(4) Armature shaft outside diameter

Measure the outside diameter of the armature shaft at four locations: front, center, end, and pinion. Replace the armature if the shaft is excessively worn.

Check the bend of the shaft; replace the armature if the bend exceeds 0.08mm (0.0031in.)

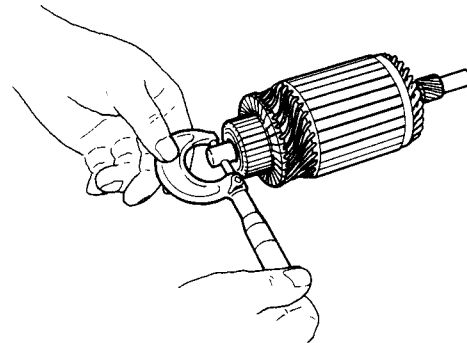

3-6.2 Field coil

(1) Open test

Check for continuity between the terminals connecting the field coil brushes. Continuity indicates the coil is open and must be replaced.

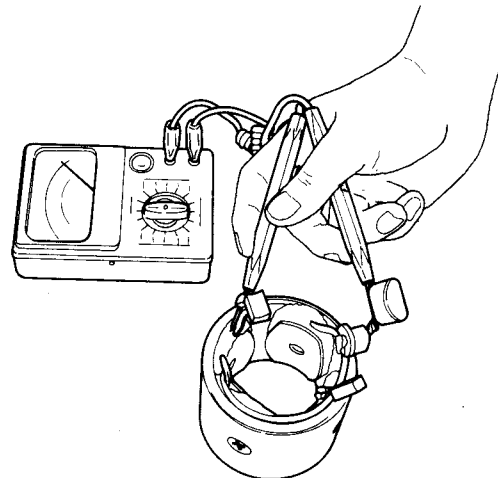

(2) Short test

Check for continuity between the yoke and any field coil terminal. Continuity indicates that the coil is shorted and it must be replaced.

(3) Cleaning the inside of the yoke

If any carbon powder or rust has collected on the inside of the yoke, blow the yoke out with dry compressed air.

*Do not remove the field coil from the yoke.

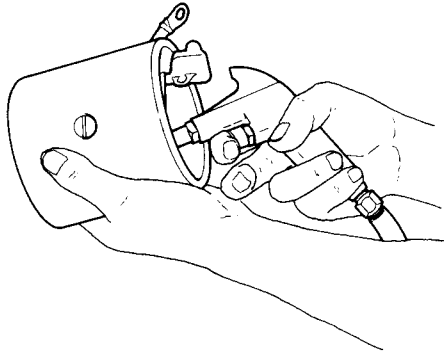

3-6.3 Brush

The brushes are quickly worn down by the motor. When the brushes are defective, the output of the motor will drop.

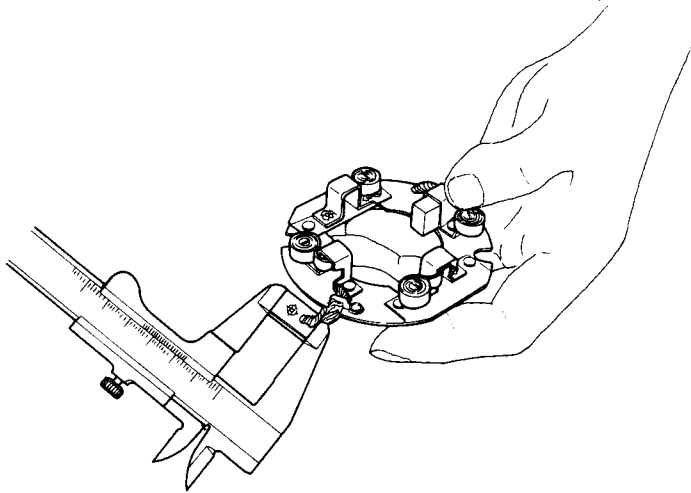

(1) Brush dimensions

Replace brushes which have been worn beyond the specified wear limit.

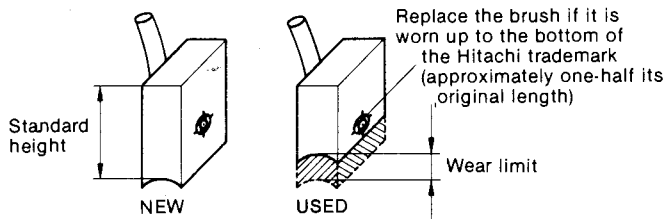

	mm (in.)
	S12-77A
Brush standard height	22 (0.8661)
Wear limit	8 (0.3150)

(2) Brush appearance and movement in brush holder

If the outside of the brush is damaged, replace it. If the movement of the brushes in the brush holder is hampered because the holder is rusted, repair or replace the holder.

(3) Brush spring

Since the brush spring pushes the brush against the commutator while the motor is running, a weak or defective spring will cause excessive brush wear, resulting in sparking between the brush and the commutator during operation. Measure the spring force with a spring balance; replace the spring when the difference between the standard value and the measured value exceeds $\pm 0.2\text{kg}$.

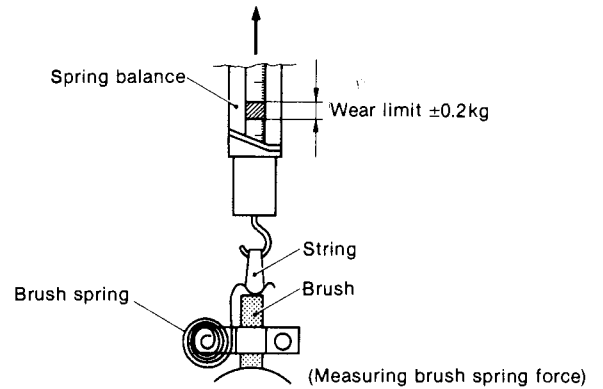

	S12-77A
Standard spring load	0.85kg (1.8737 lb)

(4) Brush holder ground test

Check for continuity between the insulated brush holder and the base of the brush holder assembly. Continuity indicates that these two points are grounded and that the holder must be replaced.

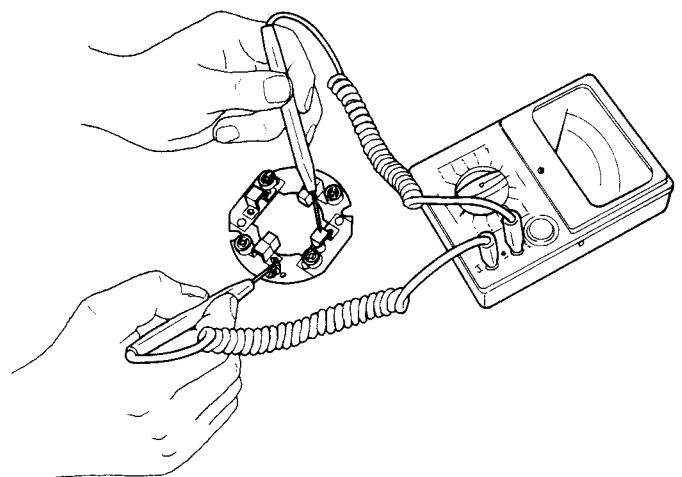

3-6.4 Magnetic switch

(1) Shunt coil continuity test

Check for continuity between the S terminal and the magnetic switch body (metal part). Continuity indicates that the coil is open and that the switch must be replaced.

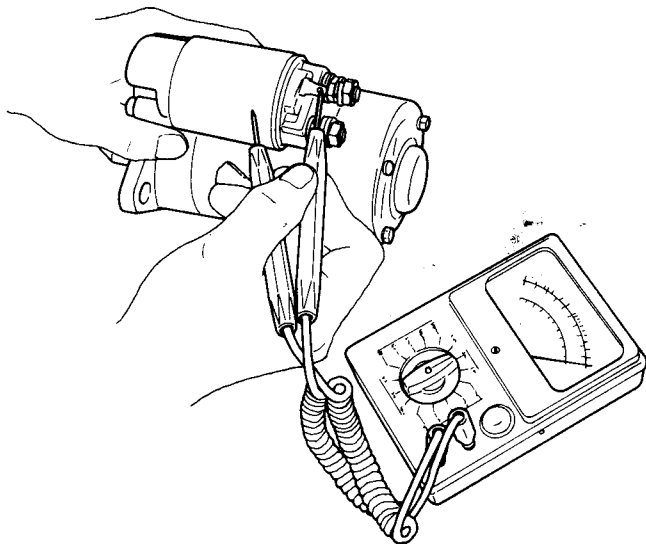

	S12-77A
Coil resistance (at 20°C)	0.590Ω

(2) Series coil continuity test

Check for continuity between the S terminal and M terminal. Continuity indicates that the coil is open and that it must be replaced.

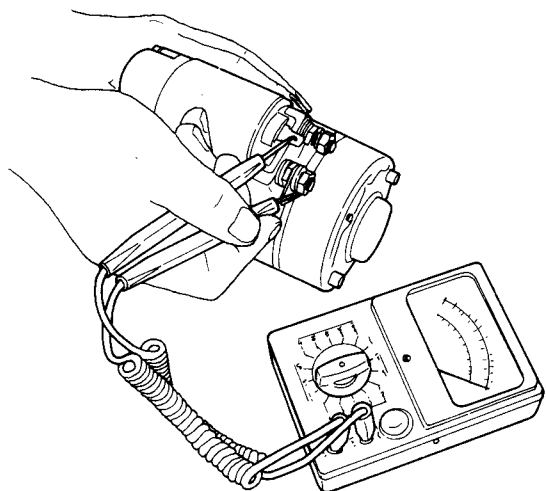

	S12-77A
Resistance value (at 20°C)	0.267Ω

(3) Contactor contact test

Push the plunger with your finger and check for continuity between the M terminal and B terminal. Continuity indicates that the contact is faulty and that the contactor must be replaced.

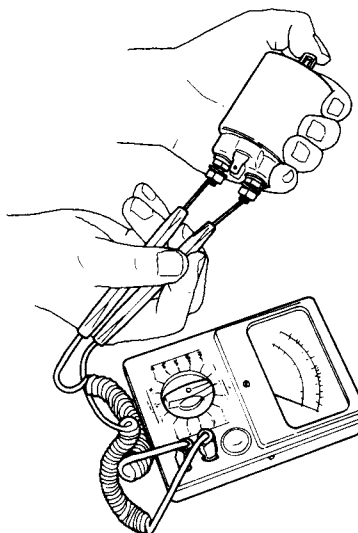

3-6.5 Pinion

- (1) Inspect the pinion teeth and replace the pinion if the teeth are excessively worn or damaged.
- (2) Check if the pinion slides smoothly; replace the pinion if faulty.
- (3) Inspect the springs and replace if faulty.
- (4) Replace the clutch if it slips or seizes.

3-7 Reassembly precautions

Reassemble the starter motor in the reverse order of disassembly, paying particular attention to the following:

(1) Torsion spring and shift lever

Hook the torsion spring into the hole in the magnetic switch and insert the shift lever into the notch in the plunger of the magnetic switch (through the torsion spring).

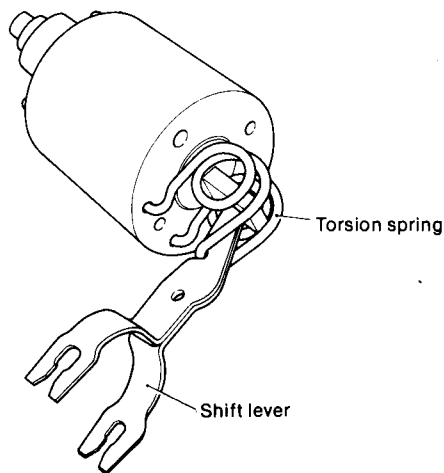

(2) Mounting the magnetic switch

Attach the shift lever to the pinion; assemble the gear case as shown below.

Do not forget to install the dust cover before assembling the gear case.

After reassembly, check by conducting no-load operation.

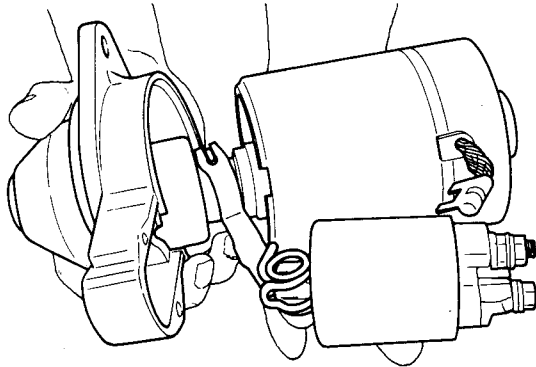

(3) Lubrication

Lubricate each bearing and spline (points indicated in the figure below) with high quality "Hitachi Electrical Equipment Grease A"

The following lubricants may be used in place of Hitachi Electrical Equipment Grease A.

Magnetic switch plunger	Shell	Aeroshell No. 7
Bearing and spline	Shell	Albania Grease No. 2

3-8 Testing

3-8.1 No load test

Test procedure

- (1) Connect the positive side of the ammeter (A) to the positive terminal of the battery, and connect the negative side of the ammeter to the B terminal of the starter.

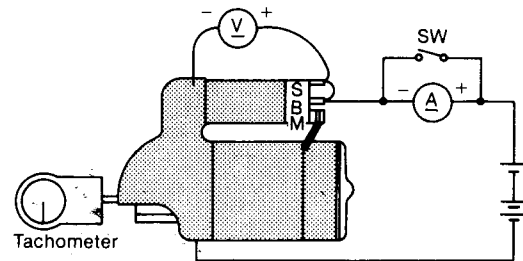

- (2) Connect the negative terminal of the battery to the body of the starter.
 - (3) Connect the positive side of the voltmeter (V) to the B terminal of the starter, and connect the negative side of the voltmeter to the body of the starter.
 - (4) Attach the tachometer.
 - (5) Connect the B terminal of the starter to the S terminal of the magnetic switch.
- The magnetic switch should begin operation, and the speed, current, and voltage should be at the prescribed values.
 - A fully charged battery must be used.
 - Since a large current flows when the starter is operated, close the protection circuit switch before initial operation, then open the switch and measure the current after the starter reaches a constant speed.

3-9 Maintenance standard

				S12-77A
Brush	Standard spring load	kg (lb)		0.85 (1.8737)
	Standard height	mm (in.)		22 (0.8661)
	Wear limit	mm (in.)		8 (0.3150)
Magnetic switch	Series coil resistance	Ω		0.267
	Shunt coil resistance	Ω		0.590
Commutator	Outside diameter	Maintenance standard	mm (in.)	$\varnothing 43$ (1.193)
		Wear limit	mm (in.)	$\varnothing 40$ (1.575)
	Difference between maximum diameter and maximum diameter	Repair limit	mm (in.)	0.4 (0.0157)
		Repair accuracy	mm (in.)	0.05 (0.002)
	Mica undercut	Maintenance standard	mm (in.)	0.2 (0.0079)
		Repair limit	mm (in.)	0.5 ~ 0.8 (0.0197 ~ 0.0315)
Standard dimension	Rear side bearing	Shaft diameter	mm (in.)	14.950 ~ 14.968 (0.5886 ~ 0.5893)
		Bearing inside diameter	mm (in.)	15.000 ~ 15.018 (0.5906 ~ 0.5913)
	Intermediate bearing	Shaft diameter	mm (in.)	20.350 ~ 20.368 (0.7972 ~ 0.7980)
		Bearing inside diameter	mm (in.)	20.500 ~ 20.518 (0.8071 ~ 0.8080)
	Pinion sliding section	Shaft diameter	mm (in.)	13.950 ~ 13.968 (0.5492 ~ 0.5499)
		Pinion inside diameter	mm (in.)	14.030 ~ 14.050 (0.5524 ~ 0.5531)
	Pinion side bearing	Shaft diameter	mm (in.)	13.950 ~ 13.968 (0.5492 ~ 0.5499)
		Bearing inside diameter	mm (in.)	14.000 ~ 14.018 (0.5512 ~ 0.5519)

3-10 Various problems and their remedies**(1) Pinion fails to advance when the starting switch is closed**

Problem	Cause	Corrective action
Wiring	Open or loose battery or switch terminal	Repair or retighten
Starting switch	Threaded part connected to pinion section of armature shaft is damaged, and the pinion does not move	Repair contacts, or replace switch
Starter motor	Threaded part connected to pinion section of armature shaft is damaged, and the pinion does not move	Replace
Magnetic switch	Plunger of magnetic switch malfunctioning or coil shorted	Repair or replace

(2) Pinion is engaged and motor rotates, but rotation is not transmitted to the engine

Problem	Cause	Corrective action
Starting motor	Overrunning clutch faulty	Replace

(3) Motor rotates at full power before pinion engages ring gear

Problem	Cause	Corrective action
Starter motor	Torsion spring permanently strained	Replace

(4) Pinion engages ring gear, but starter motor fails to rotate

Problem	Cause	Corrective action
Wiring	Wires connecting battery and magnetic switch open or wire connecting ground, magnetic switch and motor terminals loose	Repair, retighten, or replace wire
Starter motor	Pinion and ring gear engagement faulty Motor mounting faulty Brush worn or contacting brush spring faulty Commutator dirty Armature, field coil faulty Field coil and brush connection loose	Replace Remount Replace Repair Repair or replace Retighten
Magnetic switch	Contactors contact faulty Contactors contacts pitted	Replace Replace

(5) Motor fails to stop when starting switch is opened after engine starts

Problem	Cause	Corrective action
Starting switch	Switch faulty	Replace
Magnetic switch	Switch faulty	Replace

4. Alternator Standard, 12V/55A

The alternator serves to keep the battery constantly charged. It is installed on the cylinder block by a bracket, and is driven from the V-pulley at the end of the crankshaft by a V-belt.

The type of alternator used in this engine is ideal for high speed engines with a wide range of engine speeds. It contains diodes that convert AC to DC, and an IC regulator that keep the generated voltage constant even when the engine speed changes.

4-1 Features

The alternator contains a regulator using an IC, and has the following features.

(1) The IC regulator is self-contained, and has no moving parts (mechanical contact points). It therefore has superior features such as freedom from vibration, no fluctuation of voltage during use, and no need for readjustment.

Also, it is of the over-heating compensation type and can automatically adjust the voltage to the most suitable level depending on the operating temperature.

(2) The regulator is integrated within the alternator to simplify external wiring.

(3) It is an alternator designed for compactness, lightness of weight, and high output.

(4) A newly developed U-shaped diode is used to provide increased reliability and easier checking and maintenance.

(5) As the alternator is to be installed on board, the following measures are taken to provide salt-proofing.

1) The front and rear covers are salt-proofed.

2) Salt-proof paint is applied to the diode.

3) The terminal, where the inboard harness is connected to the alternator, is nickel plated.

4-2 Specifications

Model of alternator	LR155-20 (HITACHI)
Model of IC regulator	TRIZ-63 (HITACHI)
Battery voltage	12V
Nominal output	12V/55A
Earth polarity	Negative earth (⊖)
Direction of rotation (viewed from pulley end)	Clockwise
Weight	4.3kg (9.5lb.)
Rated speed	5000 rpm
Operating speed	1000 ~ 9000
Speed for 13.5V	1000 or less
Output current at 20°C	over 53A/5000 rpm
Regulated voltage	14.5 ±0.3V (Standard temperature voltage gradient, -0.01/°C)

4-3 Characteristics

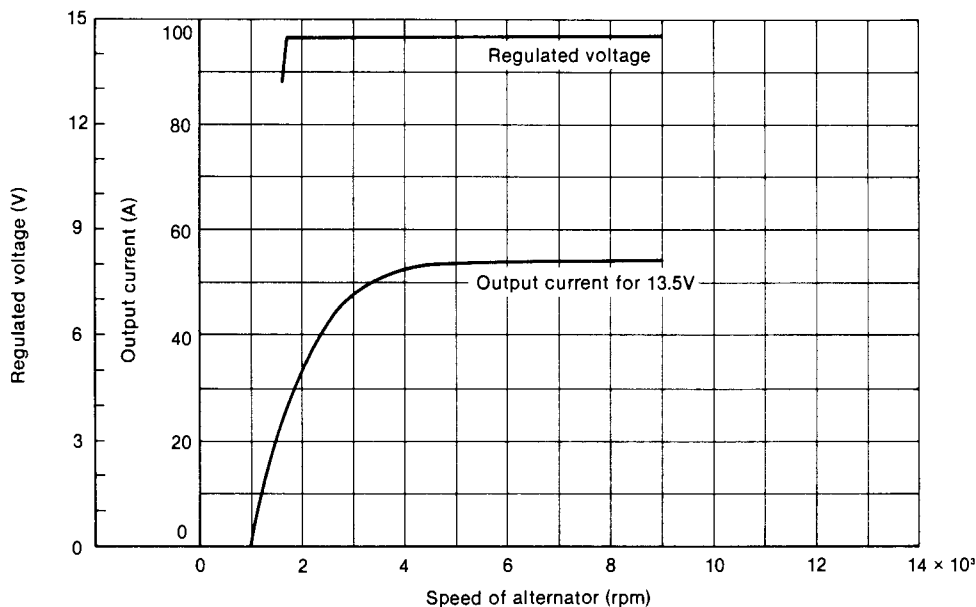

4-4 Construction

This is a standard rotating field type three-phase alternator. It consists of six major parts: the pulley, fan, front cover, rotor, stator and rear cover. The IC regulator is an integral part of the alternator.

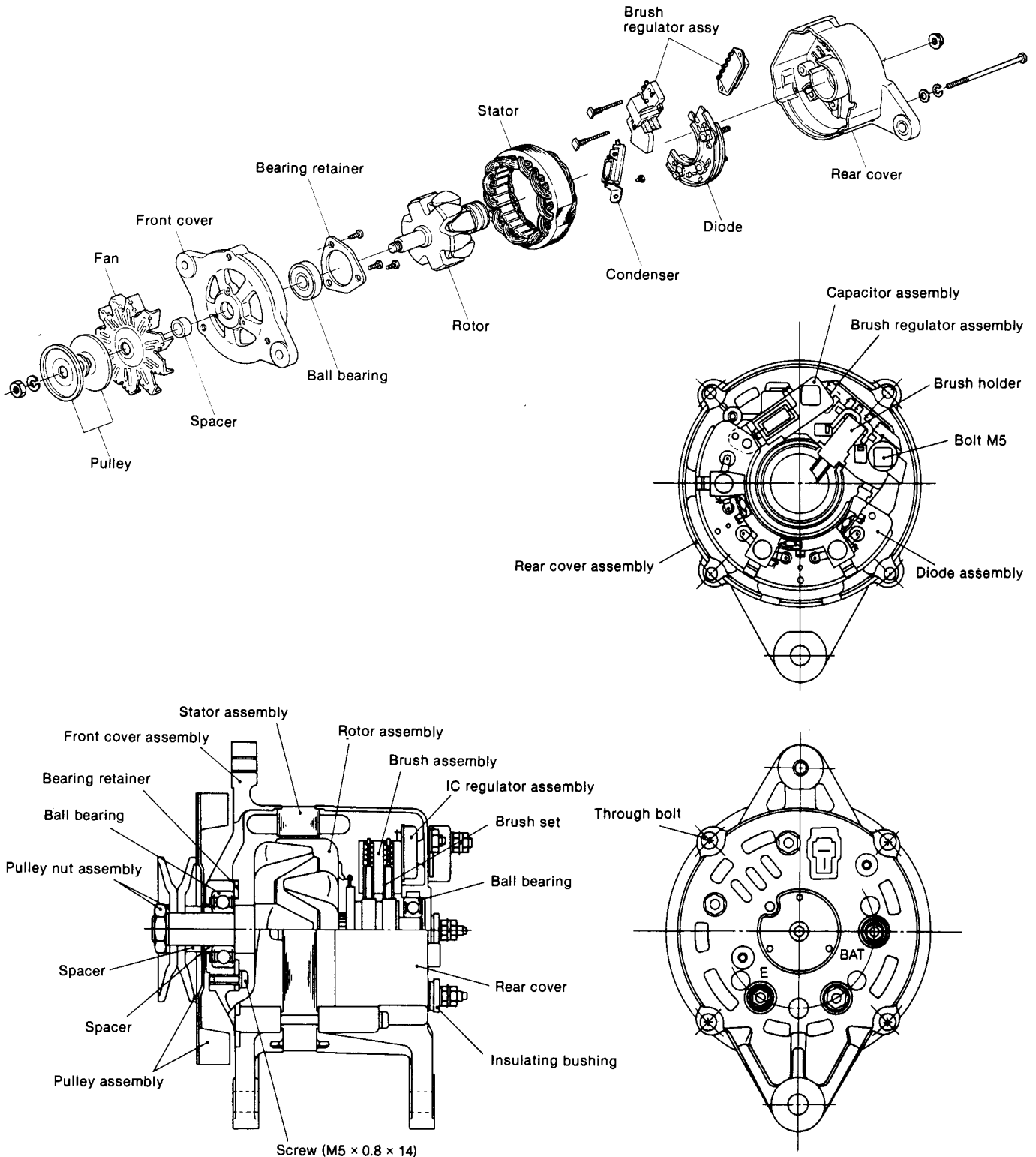

4-5 Alternator functioning

(1) IC regulator

The IC regulator is the transistor (Tr_1) which is series-connected with the rotor. The IC regulator controls the output voltage of the generator by breaking or conducting the rotor coil (exciting) current.

When the output voltage of the generator is within the standard value, the transistor (Tr_1) turns on. When the voltage exceeds the standard value, the Zener diode goes on and the transistor (Tr_1) turns off.

With the repeated turning on and off of the transistor, the output voltage is kept at the standard value. (Refer to the circuit diagram below.)

(2) Charge lamp

When the transistor (Tr_1) is on, the charge lamp key switch is turned to ON, and current flows to R_1 , R_4 and to Tr_1 to light the lamp. When the engine starts to run and output voltage is generated in the stator coil, the current stops flowing to this circuit, turning off the charge lamp.

(3) Circuit diagram

4-6 Handling precautions

(1) Be careful of the battery's polarity (+, - terminals), and do not connect the wrong terminals to the wrong cables, or the battery will be short-circuited by the generator diode.

In this case too much current will flow, the IC regulator and diodes burn out, and the wire harness will burn.

(2) Make sure of the correct connection of each terminal.

(3) When quick-charging, etc., disconnect either the battery terminal on the AC generator or the terminal on the battery.

(4) Do not short-circuit the terminals.

(5) Do not conduct any tests using high tension insulation resistance. (The diodes and IC regulator will burn out.)

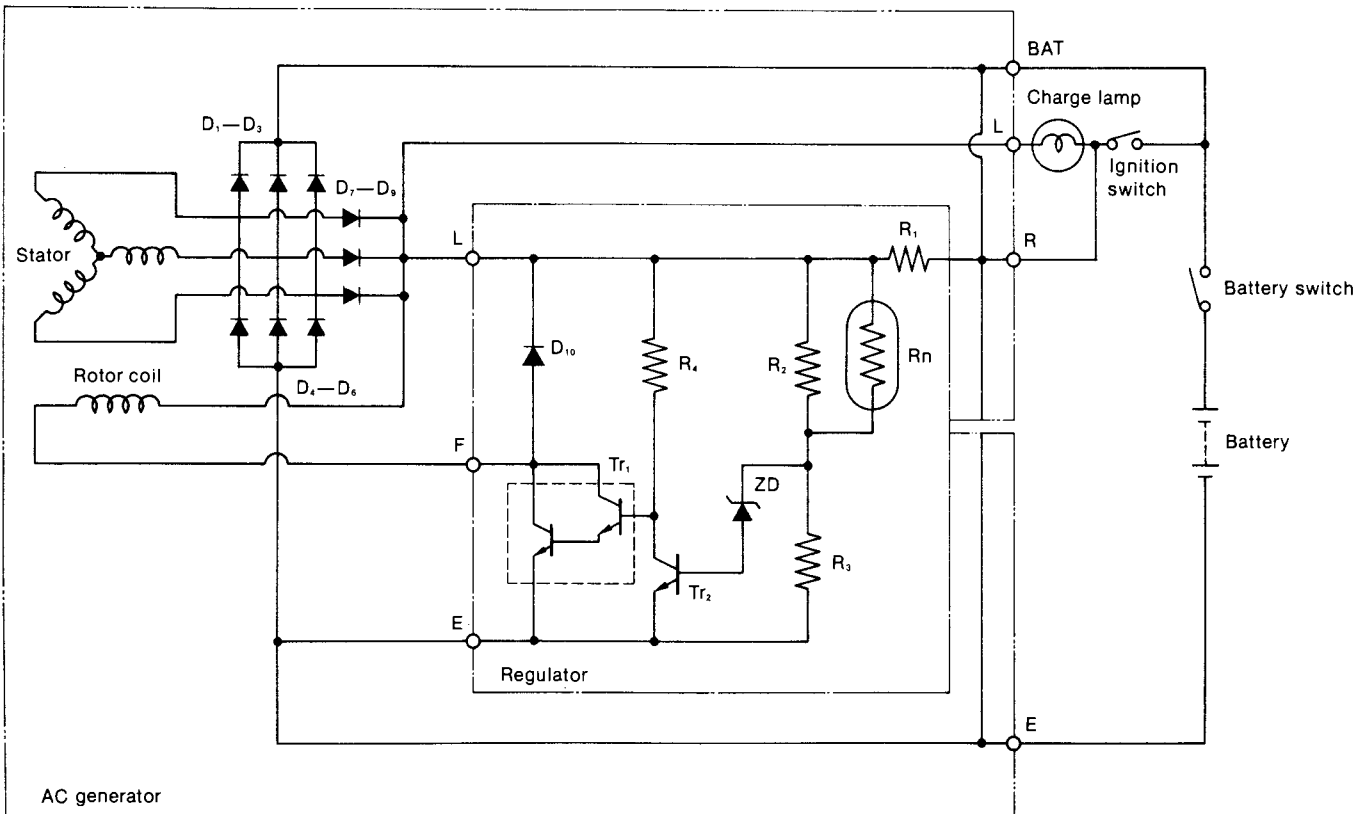

BAT:	Generator output terminal	D_1-D_6 :	Output commutation diode
D_{10} :	IC protecting diode	R_1-R_4 :	Resistor
L:	Charge lamp terminal	D_7-D_9 :	Charging lamp switching diode
ZD:	Zener diode	F:	To supply current to rotor coil
E:	Earth	Rn:	Thermistor (Temperature gradient resistance)
Tr_1, Tr_2 :	Transistor		

4-7 Disassembling the alternator

(1) Remove the through-bolt, and separate the front assembly from the rear assembly.

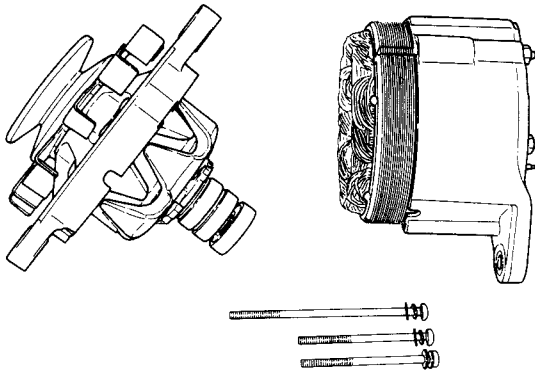

(4) Remove the nut, the brush-holder, and diode fixing nut at the BAT, and the terminal screws of the rear cover. Separate the rear cover from the stator (with the diode and brush holder).

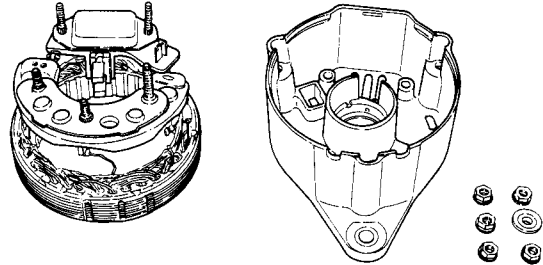

(2) Remove the pulley nut, and pull out the rotor from the front cover.

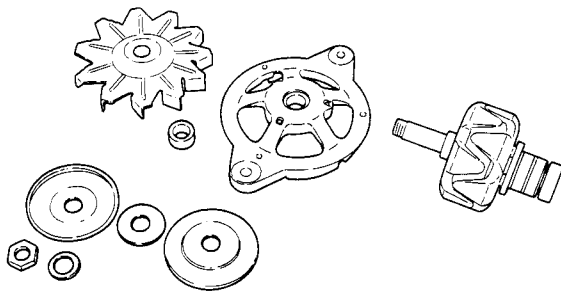

(5) Disconnect the soldered joint of the stator lead wire, and remove the diode and brush regulator assemblies from the stator at the same time.

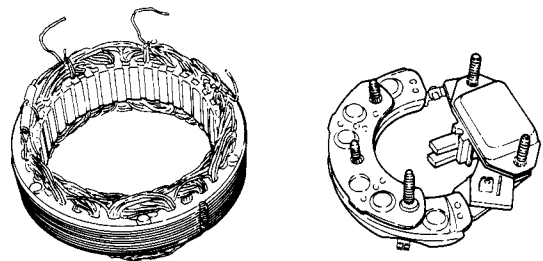

(3) Remove the $\varnothing 5\text{mm}$ ($\varnothing 0.1969\text{in.}$) screw from the front cover, and then remove the ball bearing.

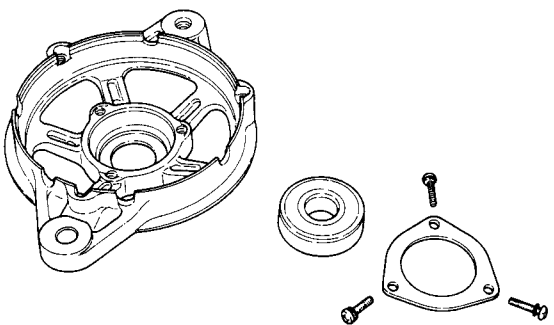

(6) Separating the regulator

1) To separate the regulator, remove the $\varnothing 3\text{mm}$ ($\varnothing 0.1181\text{in.}$) rivet which keeps the diode assembly and the brushless regulator in place, and the soldered joint of the L-terminal.

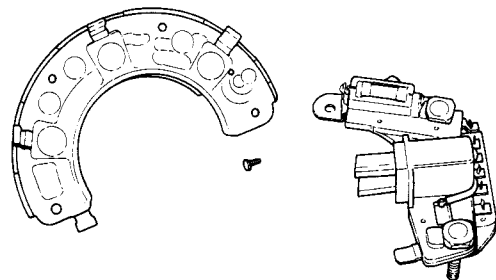

2) To replace the IC regulator, disconnect the soldered joint of the IC regulator and pull out the two bolts. Do not remove these two bolts except when replacing the IC regulator.

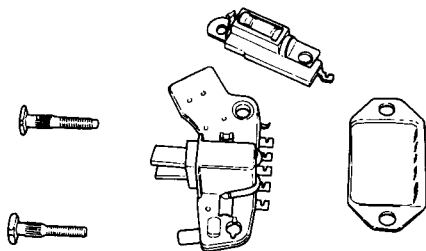

After repeating the above test, if any diode is found to be defective, replace the diode assembly. Since there is no terminal on the auxiliary diode, check the continuity between both ends of the diode.

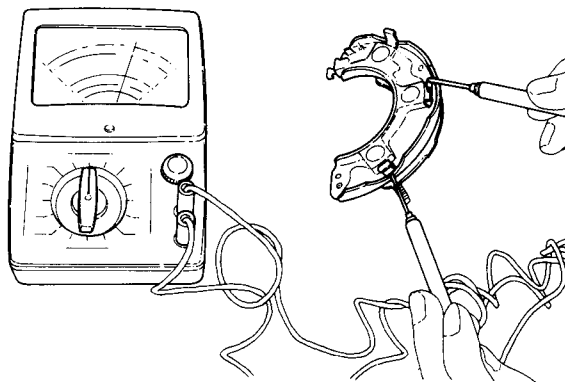

4-8 Inspection and adjustment

(1) Diode

Between terminals		BAT (+ side diode)	
	Tester wire	+ side	- side
U.V.W.	+ side	Continuity	No continuity
	- side		No continuity

Between terminals		E (- side diode)	
	Tester wire	+ side	- side
U.V.W.	+ side	No continuity	Continuity
	- side		Continuity

CAUTION: Do not use high tensile insulation resistance such as meggers, etc. for testing. The diode may burn out.

(2) Rotor

Inspect the slip ring surface, rotor coil continuity and insulation.

1) Inspecting the slip ring surface

Check if the surface of the slip ring is sufficiently smooth. If the surface is rough, grind the surface with No. 500—600 sand paper. If it is contaminated with oil, etc., wipe the surface clean with alcohol.

Slip ring outer dia.	Standard	Wear limit
	ø31.6mm (1.2441in.)	ø30.6mm (1.2049in.)

2) Rotor coil continuity test

Check the continuity in the slip ring with the tester. If there is no continuity, there is a wire break. Replace the rotor coil.

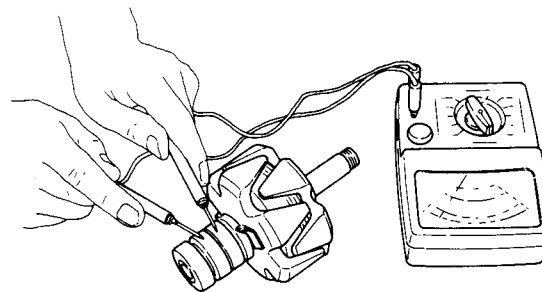

Resistance value	Approx. 3.34Ω at 20°C
------------------	-----------------------

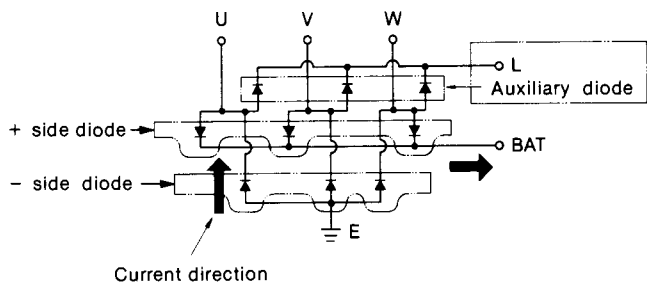

U.V.W.: terminal from the stator coil

Current flows only in one direction in the diode as shown in Fig. 181. Accordingly, when there is continuity between each terminal (e.g. BAT and U), the diode is in normal condition (photo). When there is no continuity, the diode is defective.

When the tester is connected in the reverse of above, there should be no continuity. If there is, the diode is defective.

3) Rotor coil insulation test

Check the continuity between the slip ring and the rotor core, or the shaft. If there is continuity, insulation inside the rotor is defective, causing a short with the earth circuit. Replace the rotor coil.

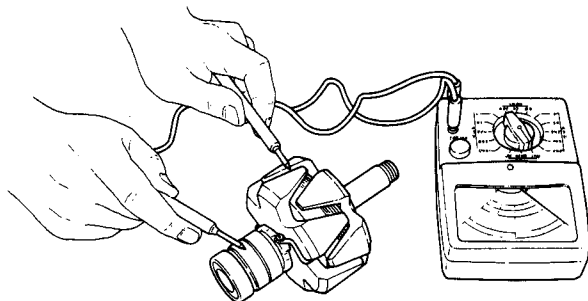

2) Stator coil insulation test

Check the continuity between the terminals and the stator core. If there is continuity, insulation of the stator coil is defective. This will cause a short-circuit with the earth core. Replace the stator coil.

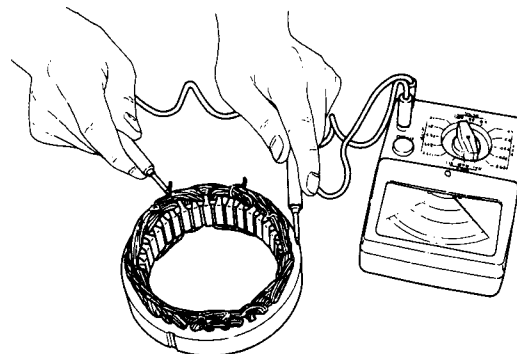

4) Check the rear side ball bearing. If the rotation of the bearing is heavy, or produces abnormal sounds, replace the ball bearing.

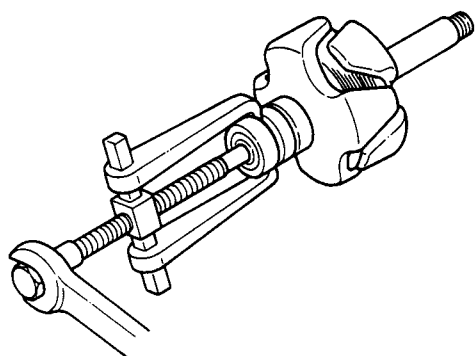

(4) Brush

The brush is hard and wears slowly, but when it is worn beyond the allowable limit, replace it. When replacing the brush, also check the strength of the brush spring. To check, push the spring down to 2mm (0.0787in.) from the end surface of the brush holder, and read the gauge.

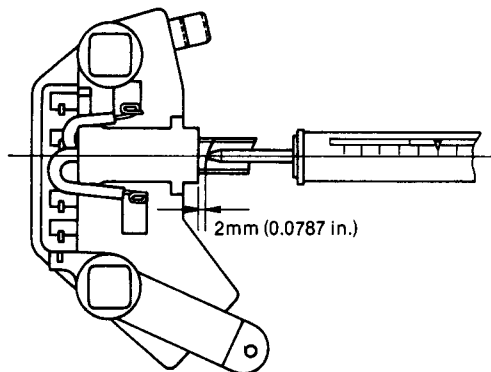

(3) Stator

1) Stator coil continuity test

Check the continuity between each terminal of the stator coil. If there is no continuity, there is a wire break in the stator coil. Replace the stator coil.

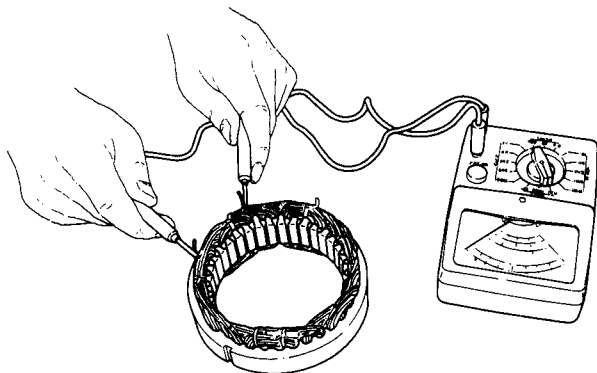

Brush spring strength	255—345g (0.56 ~ 0.76lb.)
-----------------------	---------------------------

(5) Brush wear

Check the brush length. The brush wears very little, but replace the brush if worn over the wear limit line printed on the brush.

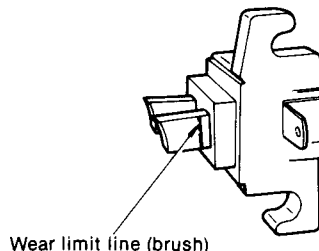

Resistance value	Approx. 0.077Ω at 20°C 1-phase resistance
------------------	--

	mm (in.)	
	Maintenance standard	Wear limit
Brush length	16 (0.6299)	9 (0.3543)

(6) IC regulator

Connect the variable resistance, two 12V batteries, resistor, and voltmeter as shown in the diagram.

1) Use the following measuring devices.

- Resistor (R₁) 100Ω, 2W, 1pc.
- Variable resistor (R_v) 0—300Ω, 12W, 1pc.
- Battery (BAT₁, BAT₂) 12V, 2pcs.
- DC voltmeter 0—30V, 0.5 class 1pc.
- (measure at 3 points)

2) Check the regulator in the following sequence, according to the diagram.

- a) Check V₃ (BAT₁ + BAT₂ voltage). If the voltage is 20—26V, both BAT₁ and BAT₂ are normal.
- b) While measuring V₂ (F-E terminal voltage), move R_v gradually from the 0-position. Check if there is a point where the V₂ voltage rises sharply from below 2.0V to over 2.0V. If there is no such point, the regulator is defective. Replace the regulator. If there is a sharp voltage rise when testing, return the R_v to the 0-position, and connect the voltmeter to the V₁ position.
- c) While measuring V₁ (voltage between L-E terminals), move R_v gradually from the 0-position. There should be a point where the voltage of V₁ rises sharply by 2—6V. Measure the voltage of V₁ just before this sharp voltage rise. This is the regulating voltage of the regulator. If this voltage of V₁ is within the standard limit, the regulator is normal. If the voltage deviates from the limit, the regulator is defective. Replace the regulator.

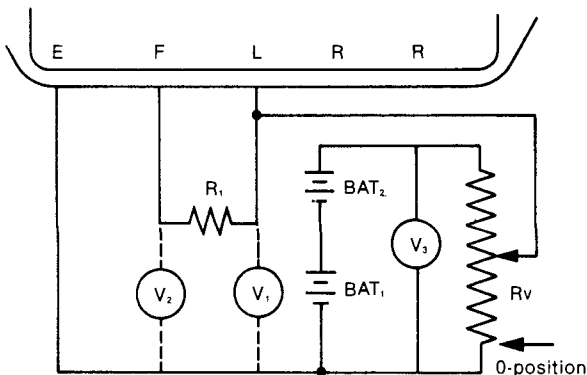

4-9 Reassembling the alternator

Reassembly is done in the reverse order of disassembly. For reassembly, be careful of the following points. (Refer to 4—7 disassembling alternator).

(1) Assembling the brush regulator

1) Solder the brush.

Position the brush as shown in the drawing and solder it. Be careful not to let the solder drip into the pig tail (lead wire).

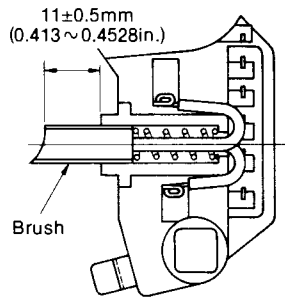

Wind the wire 1.5 times around the terminal groove.

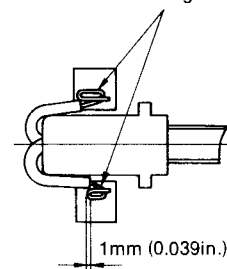

Mount the insulation tube on the terminal surface.

NOTES: 1. Use non-acid type paste.

2. The soldering iron temperature is 300 ~ 350°C.

2) Mount the IC regulator on the brush holder as illustrated, and press in the M5 bolt. Do not forget to assemble the bushing and the connecting plate at the same time.

(If the bushing is left out, the output terminal will be earthed and the battery short-circuited).

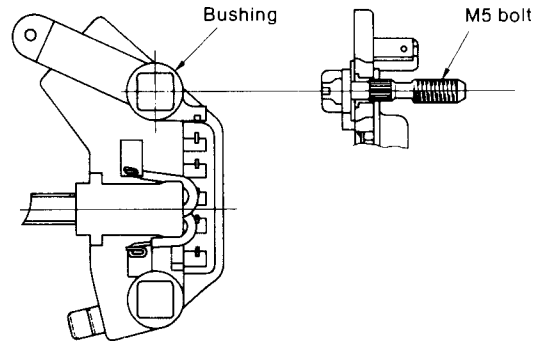

NOTES: 1. Insertion pressure is 100kg (220.5 lbs.)

2. Insert vertically.

(2) Connecting the brush regulator assembly and diode

1) Check the rivets

Place the rivets as shown in the figure, and then calk them using the calking tool.

Calking torque	500kg (1102 lbs.)
----------------	-------------------

2) Connect the brush to the diode.

Insert the brush side terminal into the diode terminal, calk it, and then solder into place.

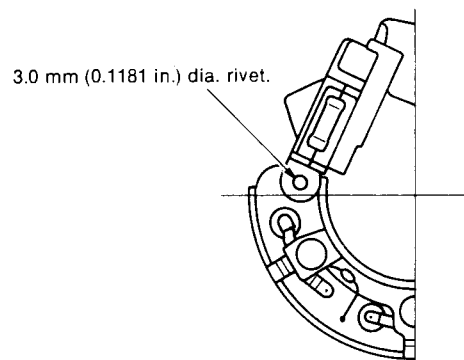

Rivetting pressure	500kg (1102 lbs.)
--------------------	-------------------

(3) Assembling the rear cover

Insert pins from the outside of the rear cover. Install the brush on the brush holder, then attach the rear cover. After assembly, pull out the pins.

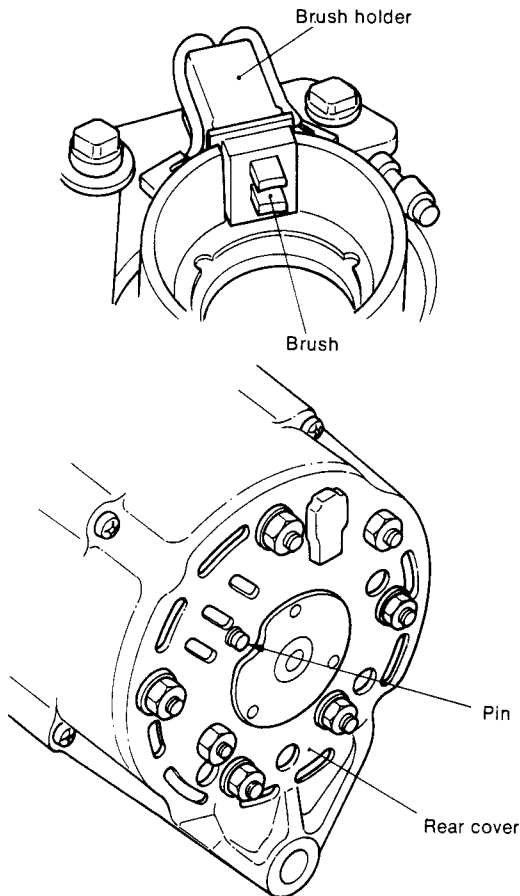

(4) Tightening torques

Positions	Tightening torque kg-cm (ft-lb)
Brush holder fixing	32—40 (2.31 ~ 2.89)
Diode fixing	32—40 (2.31 ~ 2.89)
Bearing retainer fixing	32—40 (2.31 ~ 2.89)
Pulley nut tightening	400—600 (28.93 ~ 43.40)
Through-bolt tightening	32—40 (2.31 ~ 2.89)

4-10 Performance test

Conduct a performance test on the reassembled AC generator as follows. The following is the circuit for the performance test.

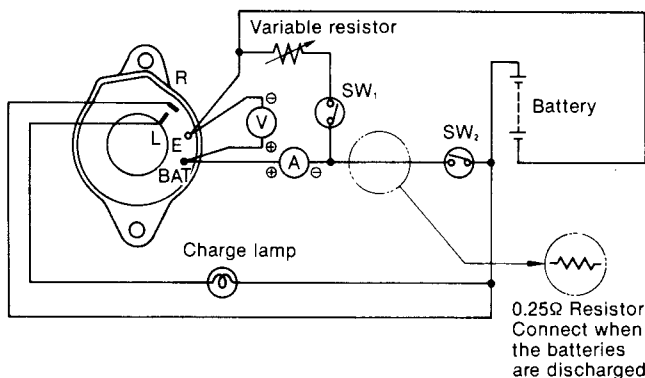

(1) Measuring devices

DC voltmeter	0—15V or 0—30V, 0.5 Class, 1pc.
DC ammeter	0—100A, 1.0 Class, 1pc.
Variable resistor	0—0.25Ω, 1kW, 1pc.
Lamp	12V, 3W
100Ω resistor	3W
0.25Ω resistor	25W

(2) Measuring the regulating voltage

- 1) When measuring devices are connected in the performance test circuit as shown above, the charge lamp lights.
- 2) Close SW₂ while keeping SW₁ open and run the AC generator. When the revolutions of the generator are gradually raised, the charge lamp goes off.
- 3) Raise the revolutions of the AC generator, and read the voltmeter gauge when the revolutions reach about 5,000 rpm.

NOTES: 1. Make sure that the ammeter indication at this time is less than 5A. If the indication is over 5A, connect the 0.25Ω resistor. The voltmeter indication at this time must be within the prescribed regulating voltage value.

2. Raise the AC generator revolutions high to make sure the regulating voltage does not fluctuate along with changes in the revolution speed.

(3) Precautions for measuring the regulating voltage

- 1) When measuring the voltage, measure the voltage between the AC generator BAT terminal, or Battery + terminal, and AC generator E-terminal.
- 2) Use a fully charged battery.
- 3) Measure the voltage quickly.
- 4) Keep SW₁ open for measurement.

4-11 Troubleshooting

(1) Charging failure

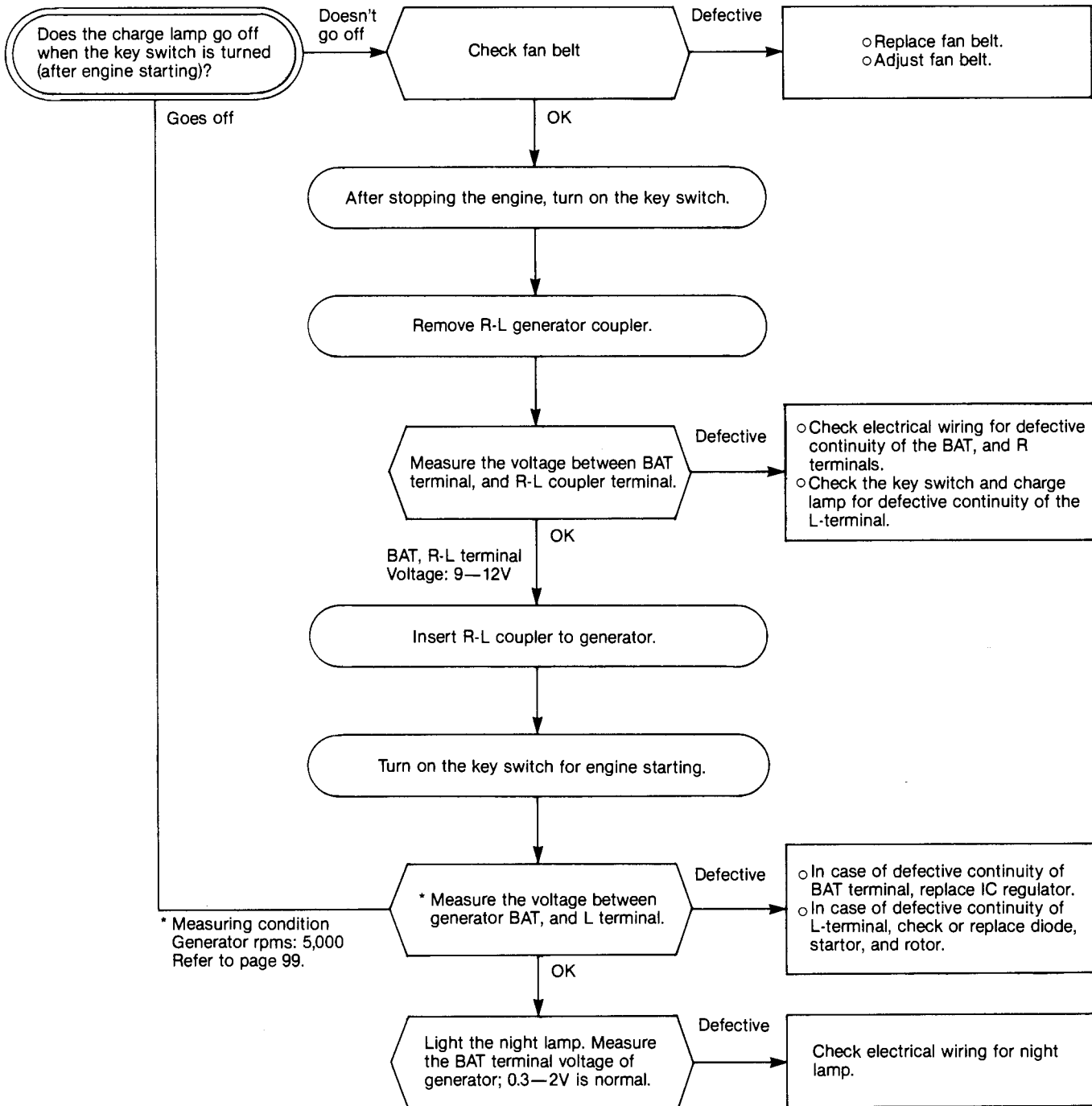

(2) Overcharging

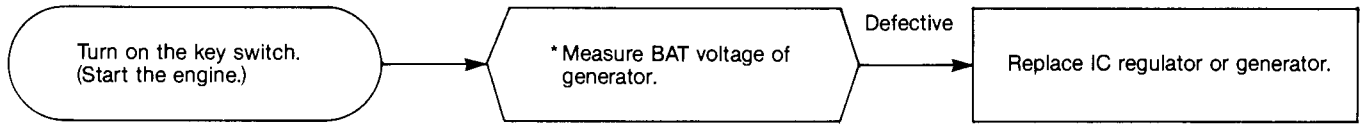

(3) Charge lamp failure

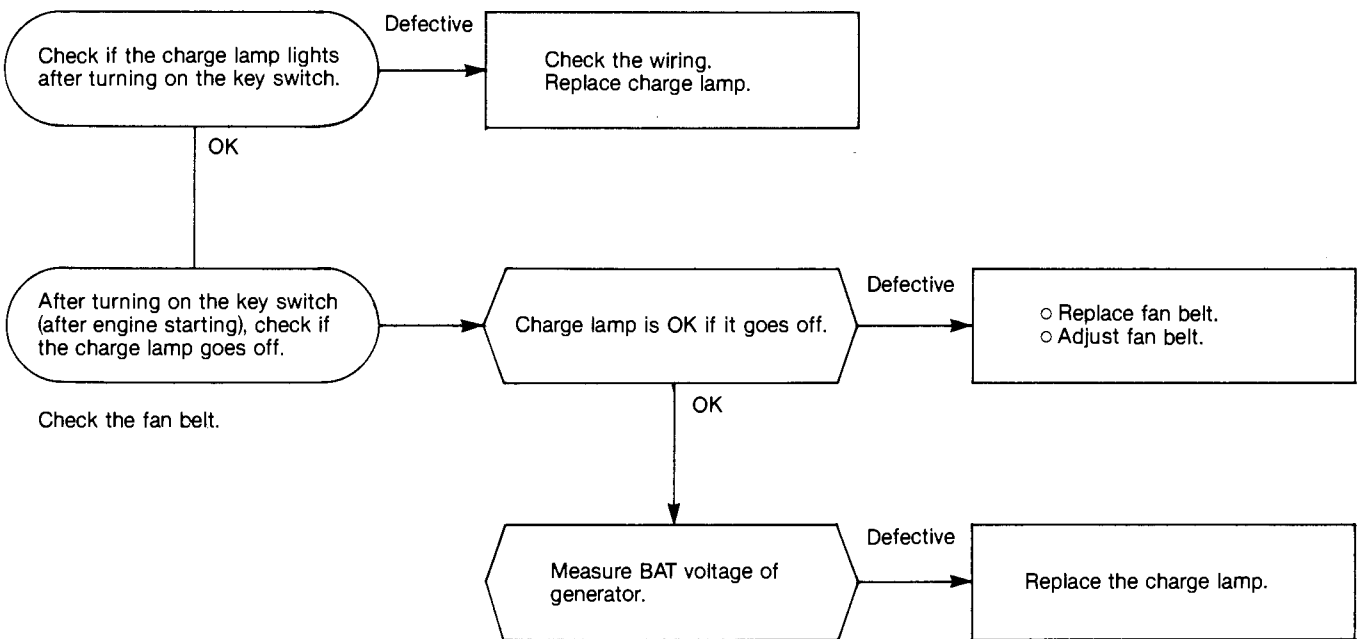

5. Instrument panel and wiring codes

There are three types of instrument panels and wire harnesses and expansion (extension) cords as follows:
 Make sure to use the correct parts when making replacements.

5-1 B-type instrument panel and wire harness

5-1.1 B-type instrument panel

Type	B-type	C-type	D-type
Instrument panel	124411-91190	129470-91100	124411-91180
Wire harness	129470-77920	129470-77930	
Extension cord 4M	129772-77500	129470-77500	
Extension cord 2M	129470-77510	129470-77520	
Extension cord 6M	129470-77530	129470-77540	

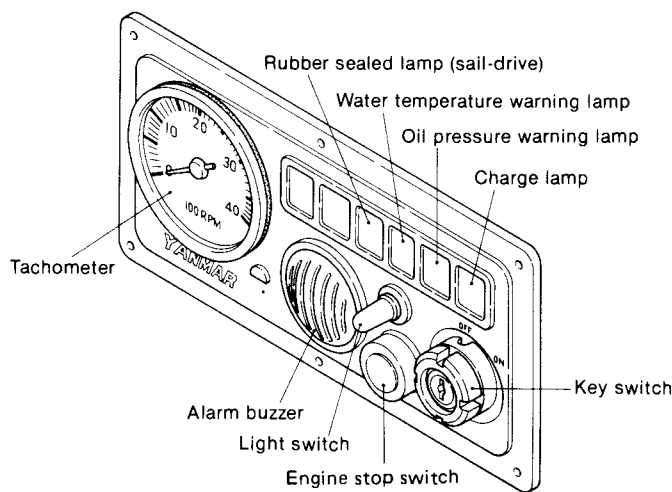
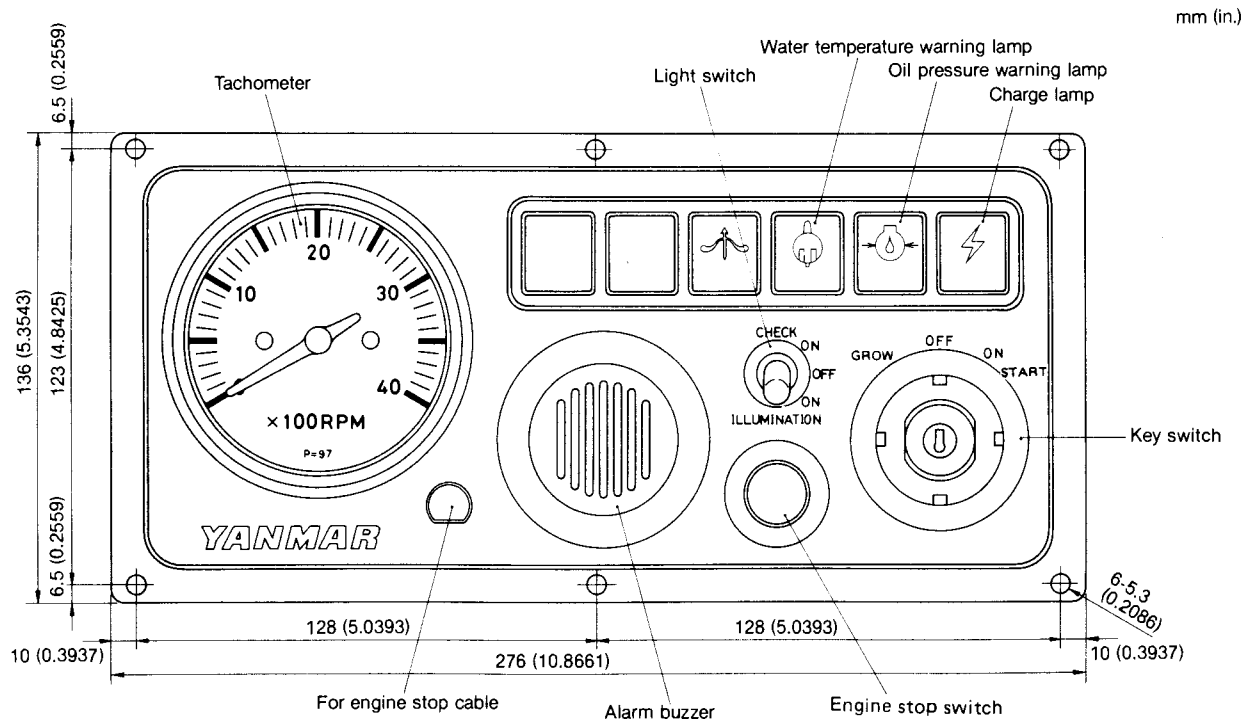

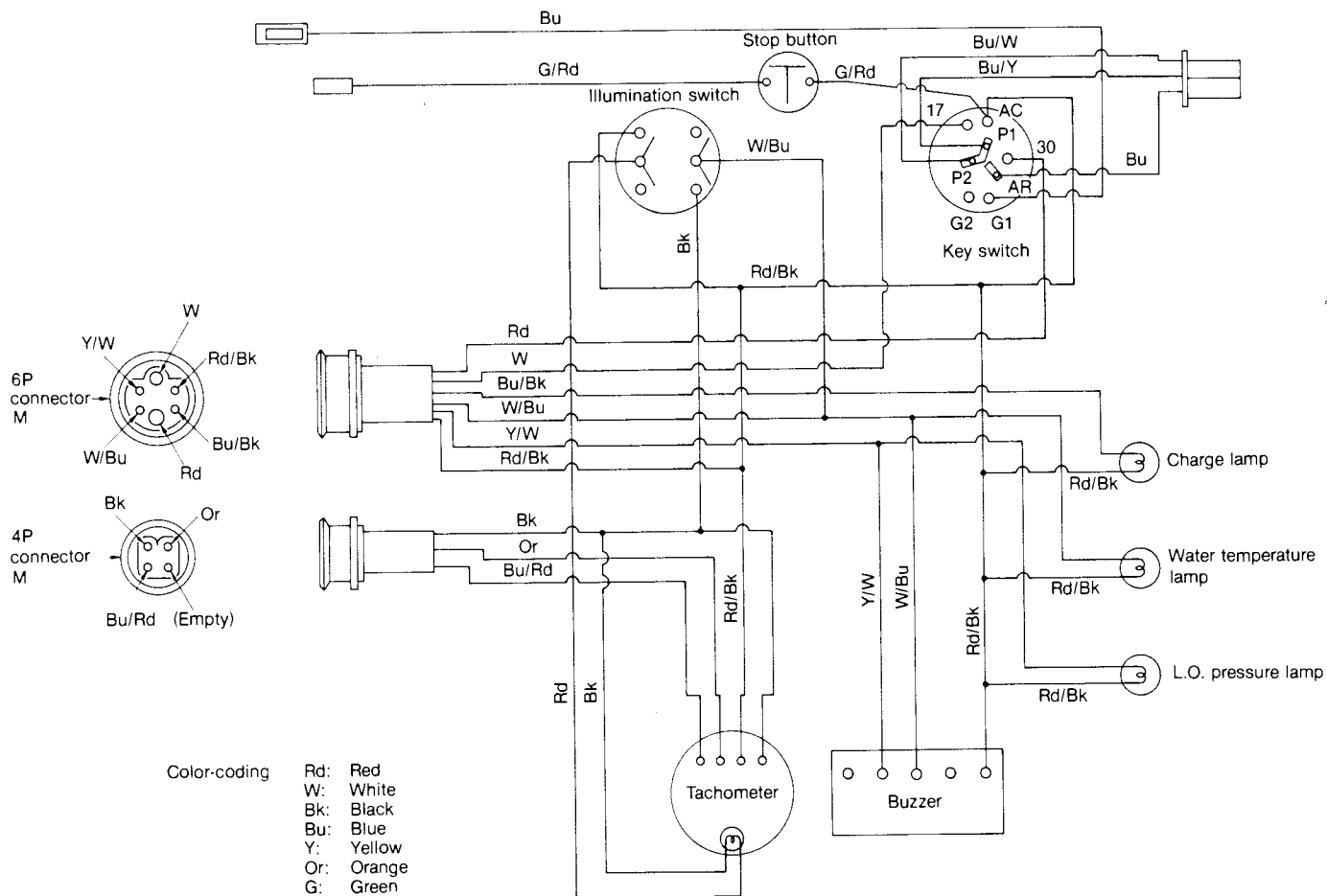

5-1.2 Wire harness for B-type instrument panel

5-1.3 Extension cord for B-type instrument panel

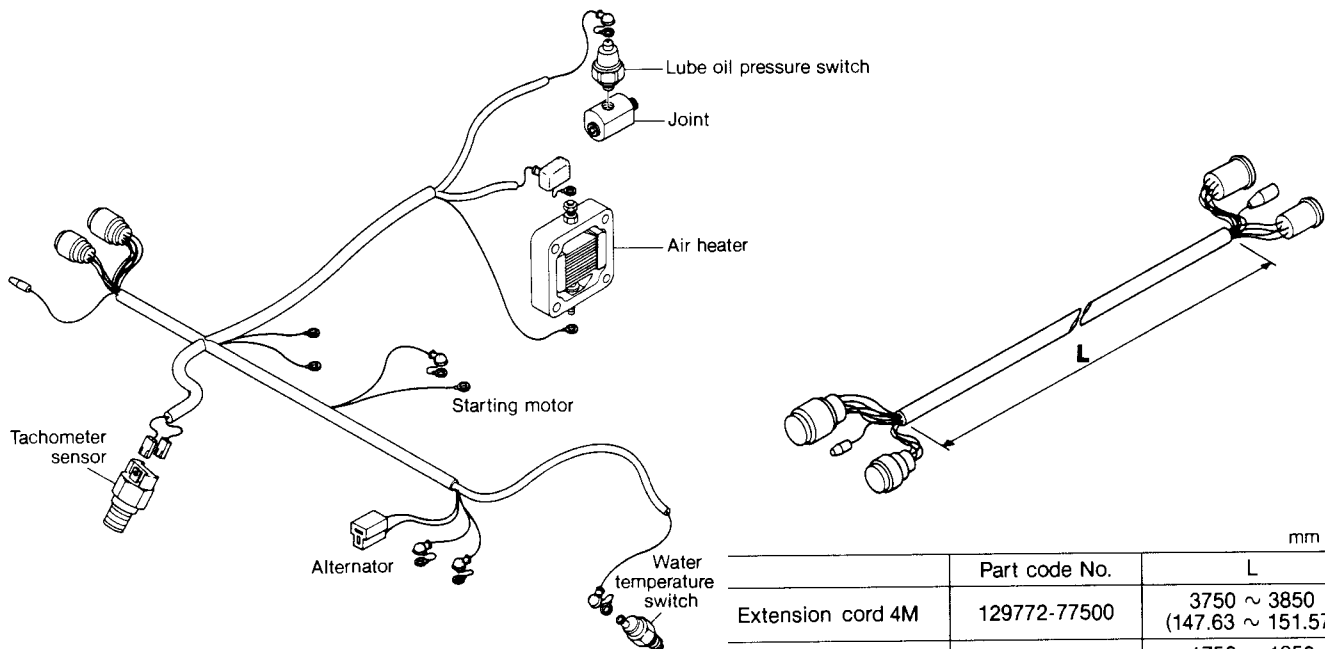

	Part code No.	L mm (in.)
Extension cord 4M	129772-77500	3750 ~ 3850 (147.63 ~ 151.57)
Extension cord 2M	129470-77510	1750 ~ 1850 (68.89 ~ 72.83)
Extension cord 6M	129470-77530	5750 ~ 5850 (226.38 ~ 230.31)

5-2 C-type, D-type instrument panel and wire harness

5-2.1 C-type instrument panel

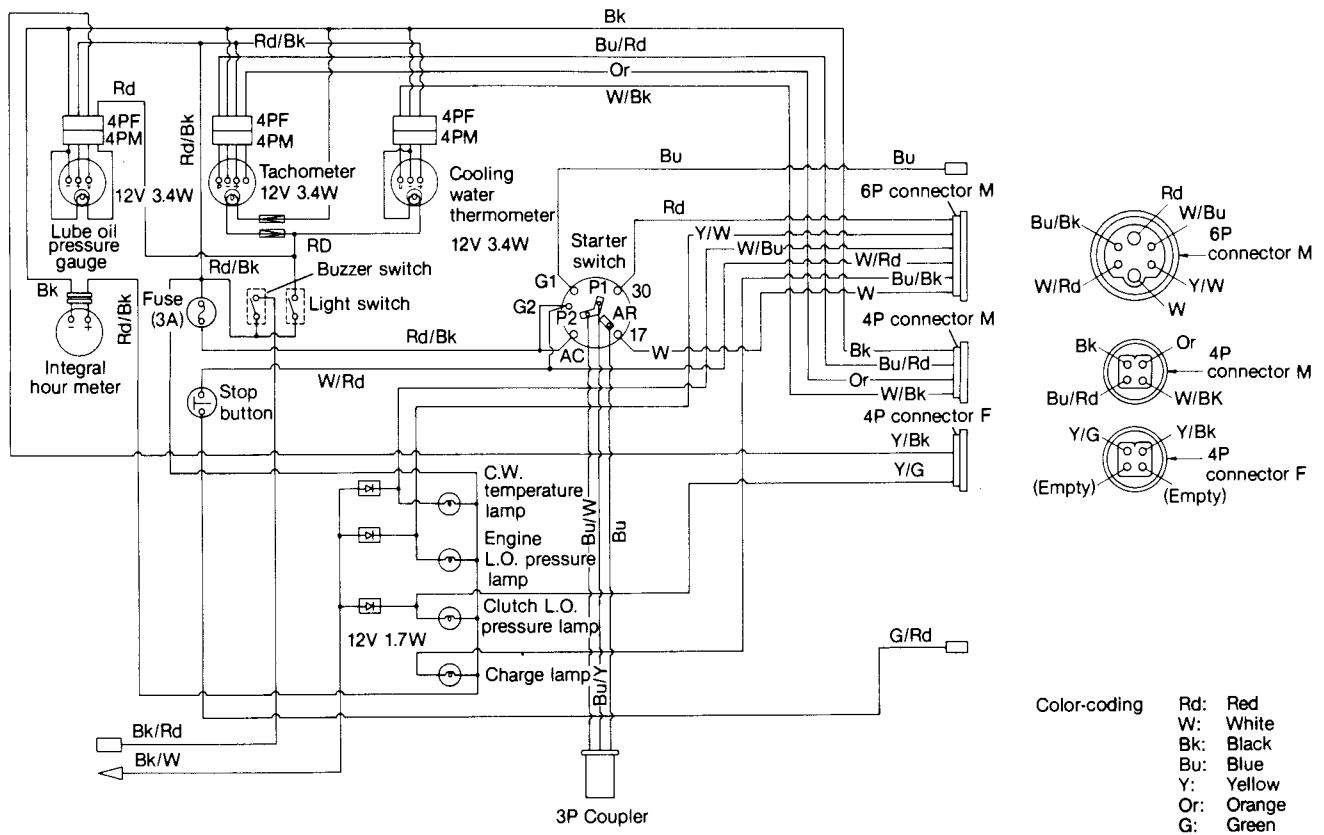
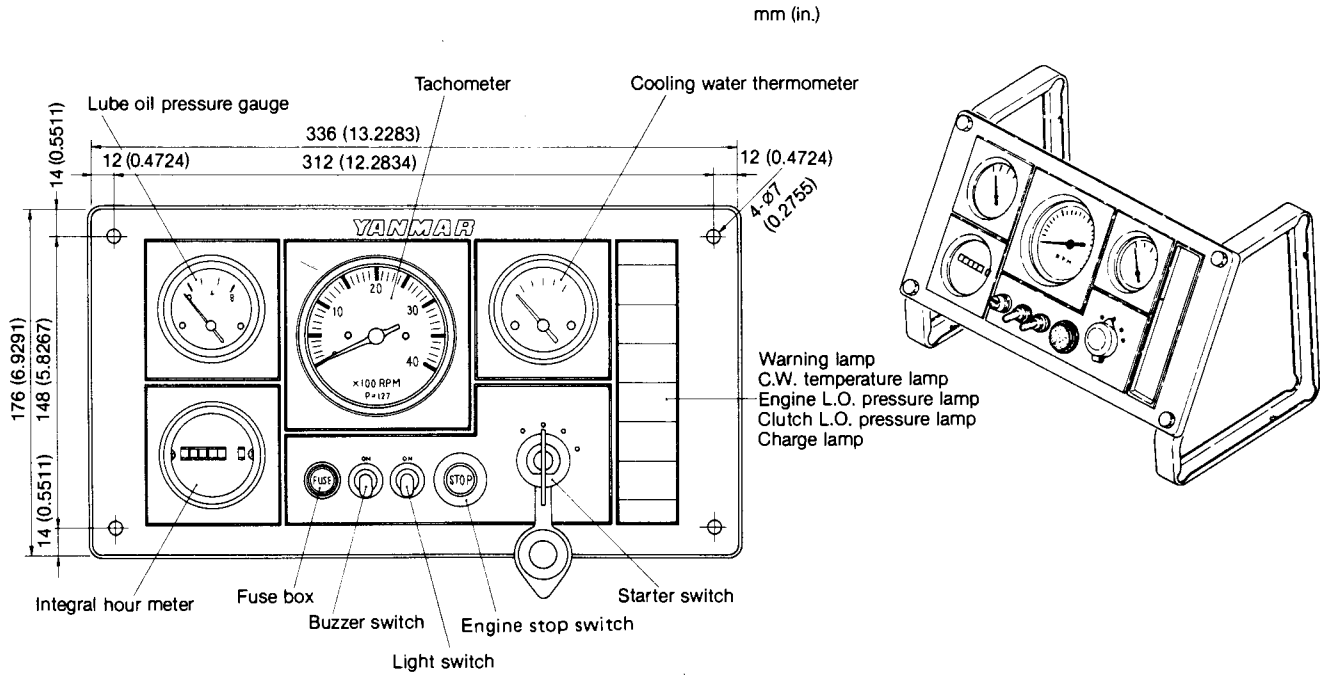

5-2.2 D-type instrument panel

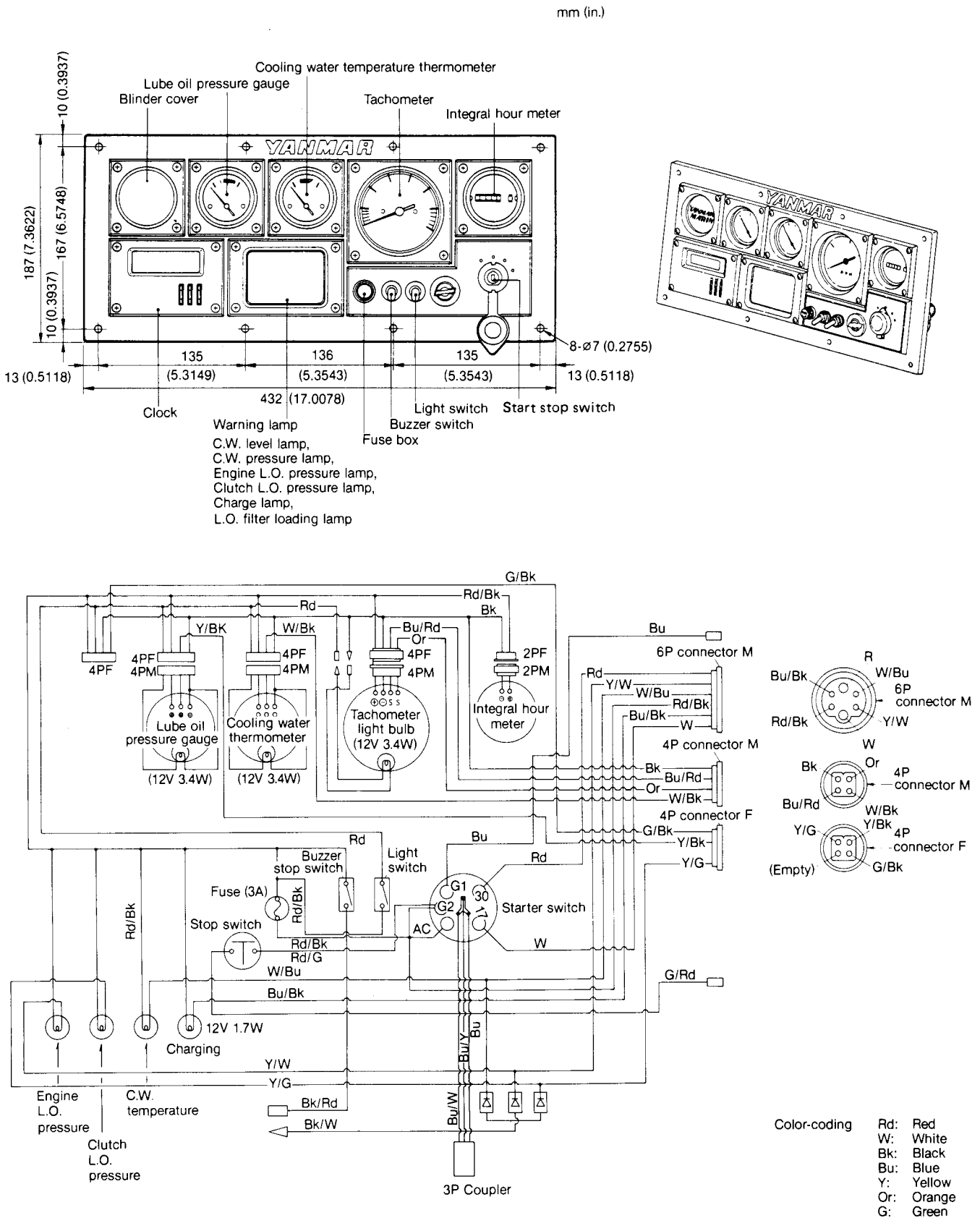

5-2.3 Wire harness for C-type and D-type instrument panel

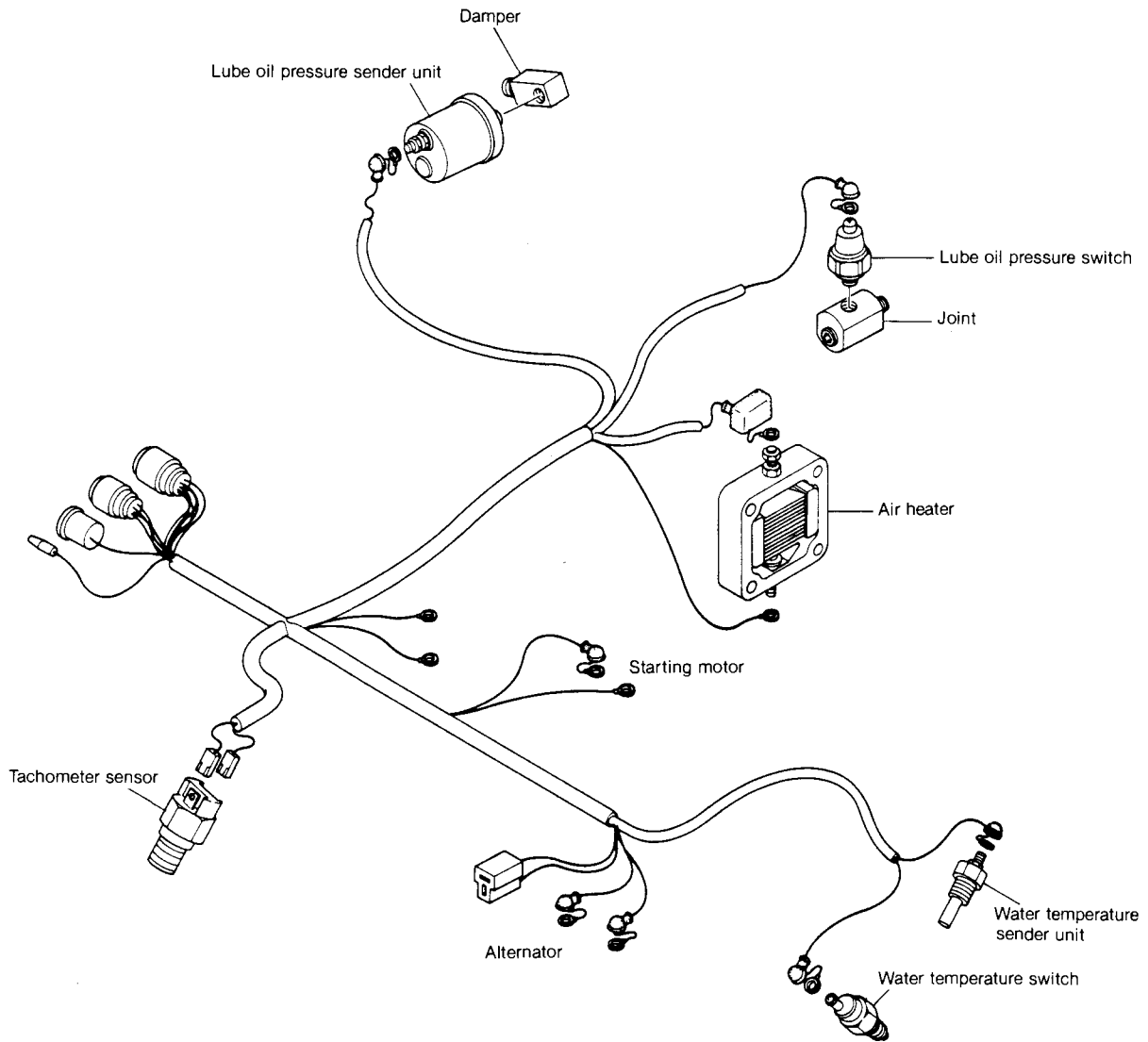

5-2.4 Extension cord for C-type and D-type instrument panel

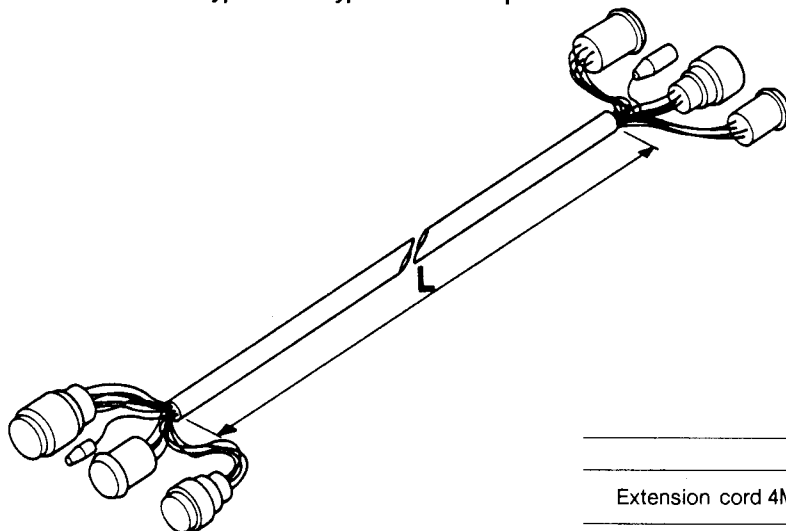

	Part code No.	L mm (in.)
Extension cord 4M	129470-77930	3750 ~ 3850 (147.63 ~ 151.57)
Extension cord 2M	129470-77520	1750 ~ 1850 (68.89 ~ 72.83)
Extension cord 6M	129470-77540	5750 ~ 5850 (226.38 ~ 230.31)

6. Warning Devices

6-1 Oil pressure alarm

If the engine oil pressure is below 0.1 ~ 0.3 kg/cm² (1.42 ~ 4.26 lb/in.²), with the main switch in the ON position, the contacts of the oil pressure switch are closed by a spring, and the lamp is illuminated through lamp → oil pressure switch → ground circuit system. If the oil pressure is normal, the switch contacts are opened by the lubricating oil pressure and the lamp remains off.

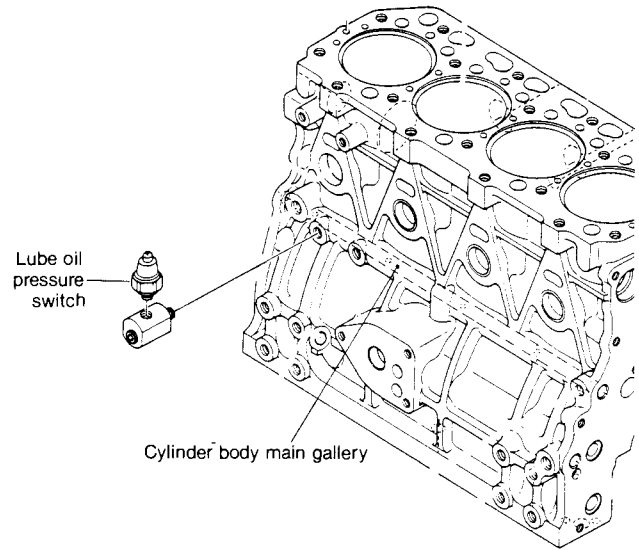
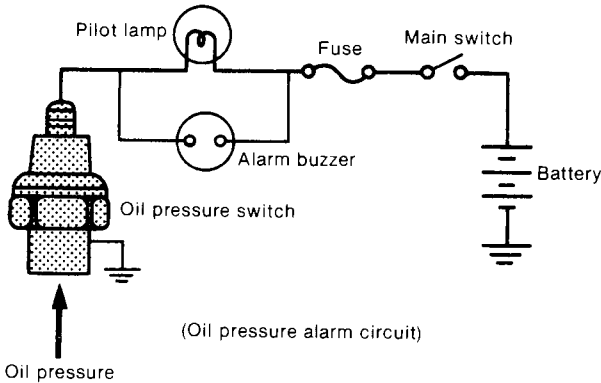

Oil pressure switch

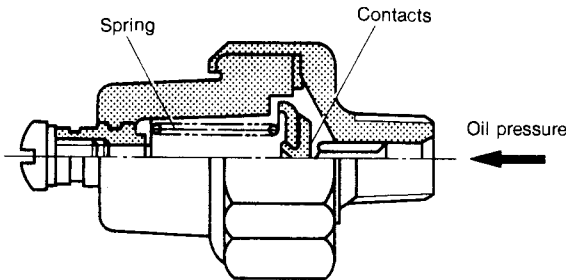

Part No.	124060-39451
Rated voltage	12V
Operation pressure	0.1 ~ 0.3kg/cm ² (1.422 ~ 4.266lb/in. ²)
Lamp capacity	5W

Inspection

Problem	Inspection item	Inspection method	Corrective action
Lamp not illuminated when main switch set to ON	1. Oil pressure lamp blown out	(1) Visual inspection	Replace lamp
	2. Operation of oil pressure switch	(2) Lamp not illuminated even when main switch set to ON position and terminals of oil pressure switch grounded	Replace oil pressure switch
Lamp not extinguished while engine running	1. Oil level low	Lamp illuminated when checked as described in (2) above	Add oil
	2. Oil pressure low	Stop engine and check oil level with dipstick	Repair bearing wear and adjust regulator valve
	3. Oil pressure faulty	Measure oil pressure	Replace oil pressure switch
	4. Wiring between lamp and oil pressure switch faulty	Switch faulty if abnormal at (1) and (2) above	Cut the wiring between the lamp and switch and wire with separate wire

6-2 Cooling water temperature alarm

A water temperature lamp and water temperature gauge, backed up by an alarm in the instrument panel, are used to monitor the temperature of the engine cooling water. A high thermal expansion material is set on the end of the water temperature unit. When the cooling water temperature reaches a specified high temperature, the contacts are closed, and an alarm lamp and buzzer are activated at the instrument panel.

Operating temperature	ON	93 ~ 97°C (199 ~ 206°F)
	OFF	88°C (190°F) or high
Electric capacity	DC 12V, 1A	
Response time	with in 60 sec.	
Indication color	Green	
Part code No.	127610-91350	
Tightening torque	2.40 ~ 3.20kg-m (17.35 ~ 23.14ft-lb)	

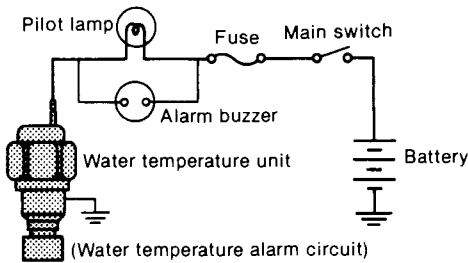
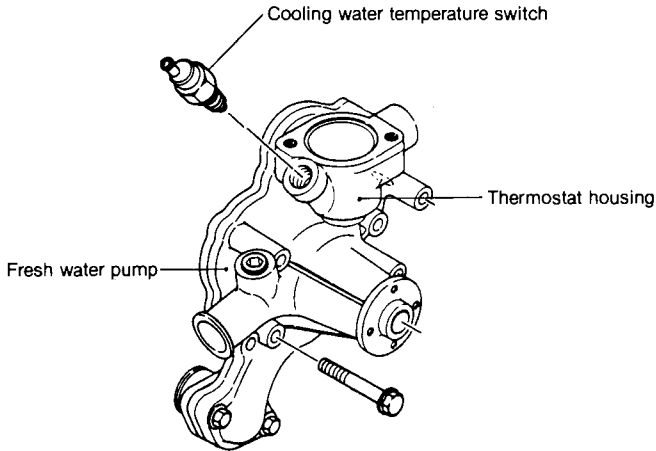

6-3 Sender unit for lube oil pressure gauge

The sender unit for the lube oil pressure gauge has a mounting seat for mounting on the lube oil filter bracket. Oil pressure is measured when the oil enters into the main gallery after being fed from the lube oil cooler and passing through oil pressure control valve. Make sure to mount a vibration damper when mounting the oil pressure sender unit.

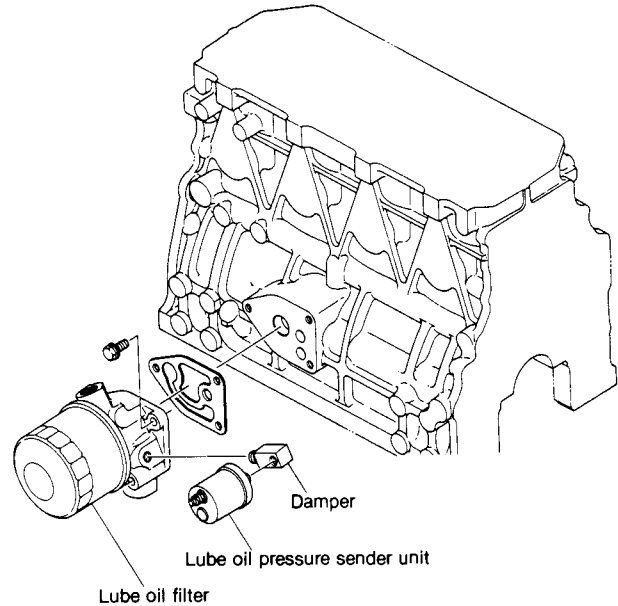
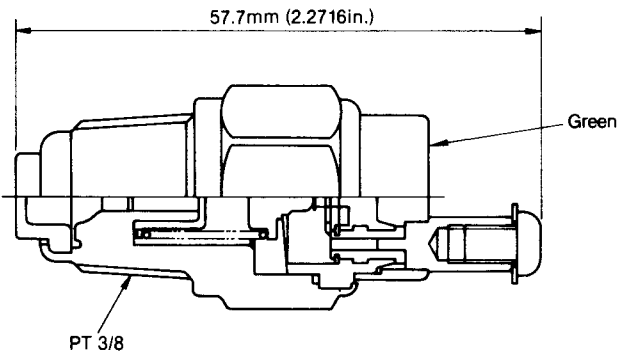

Lube oil pressure sender unit

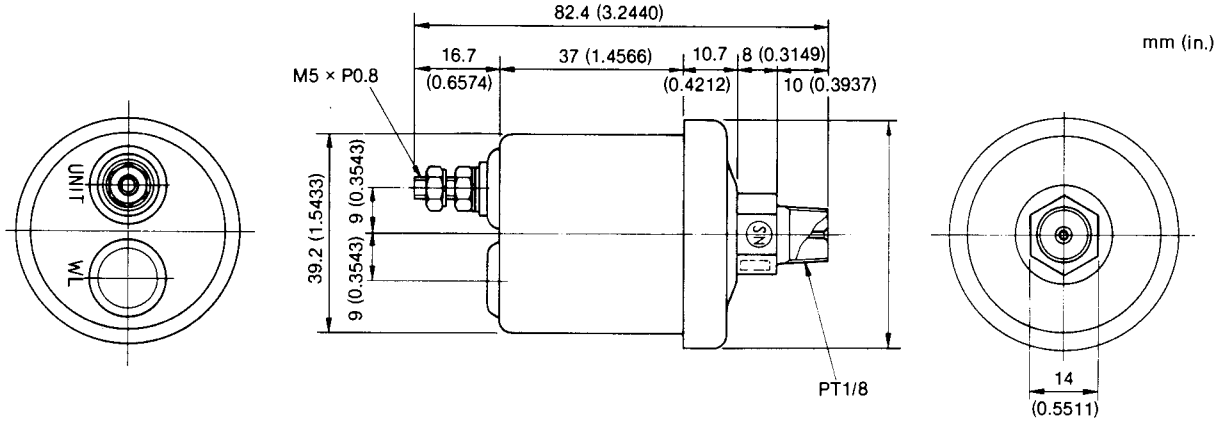

Damper

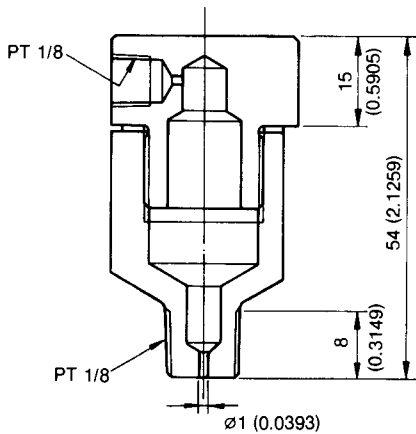

Type	Resistance switch
Rated voltage	DC 12/DC 24
Max. operating pressure	8kg/cm ² (113.76 lb/in. ²)
Part code No.	144626-91560

6-4 Sender unit for the cooling water temperature gauge

The water temperature sender unit has a mounting seat for mounting on the fresh water pump unit. Water temperature is measured when the cooling water flows into the thermostat housing after leaving the cylinder head.

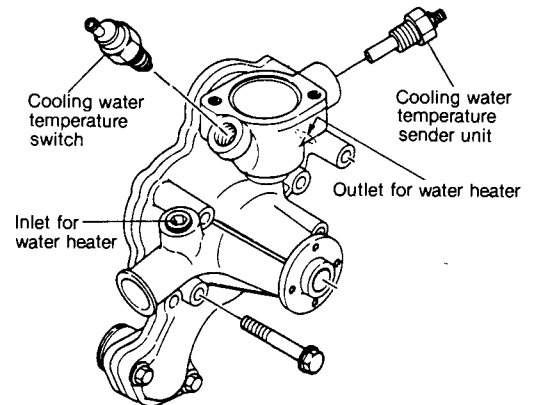
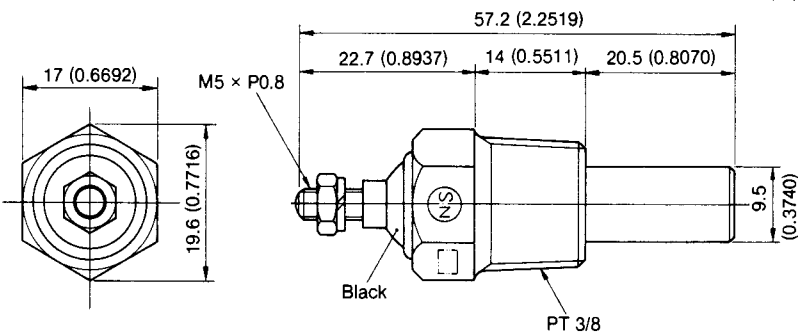

Type	Thermistor switch
Rated voltage	12V/24V
Part code No.	144626-91570

7. Air Heater (Optional)

An air heater is available for warming intake air during starting in cold areas during winter. The air heater is mounted between the intake manifold and intake manifold coupling.

The device is operated by the glow switch on the instrument panel.

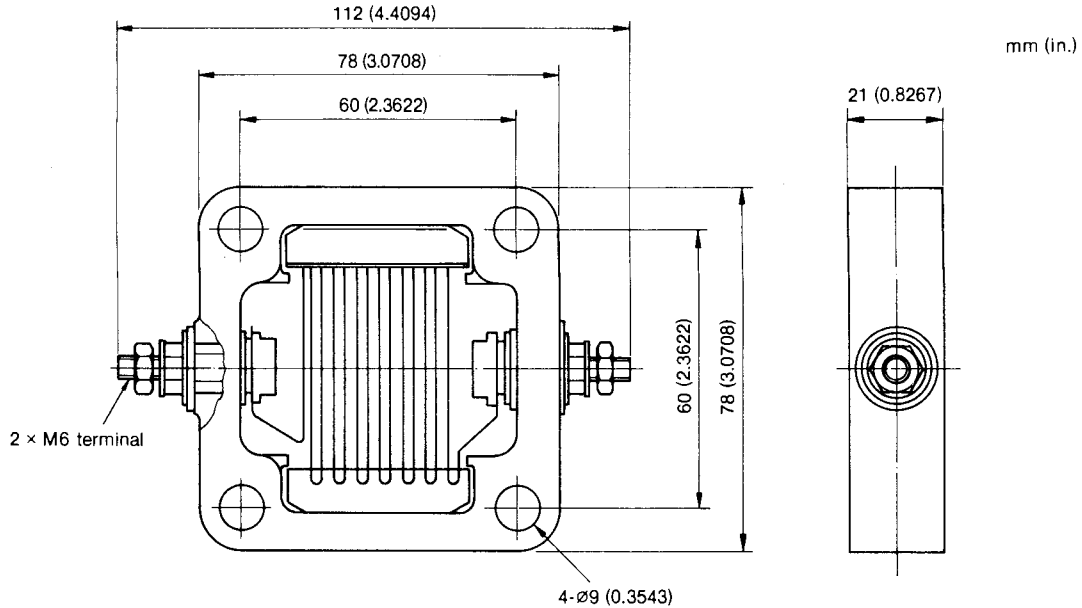
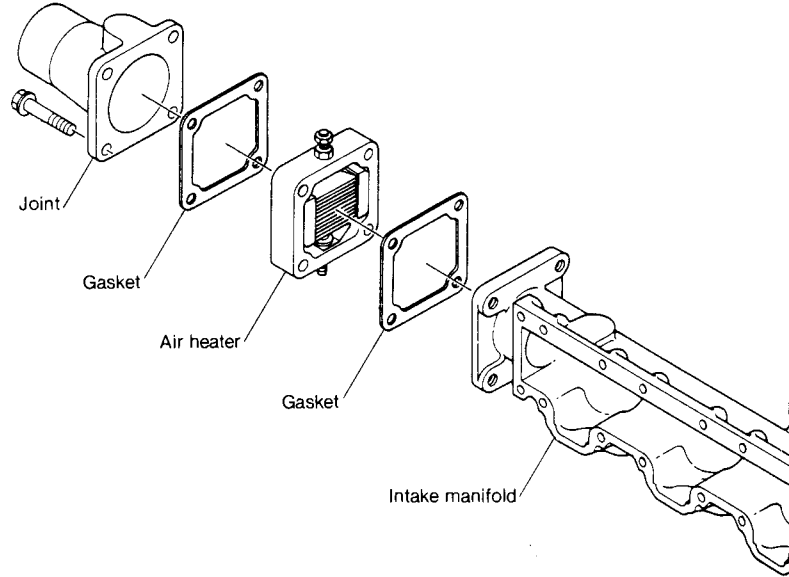

Rated output	400W
Rated current	33.3A
Rated voltage	DC 12V
Rated operating time	Engine operation: 60 sec. Engine stop: 30 sec.
Range of operating temperature	+50°C ~ 30°C (122°F ~ -22°F)
Part code No.	129400-77500

8. Electric type Engine Stopping Device (Optional)

To employ the electric engine stop device, the stop lever of the fuel injection pump is connected to the solenoid with a connection metal.

The device is operated by the stop switch on the instrument panel.

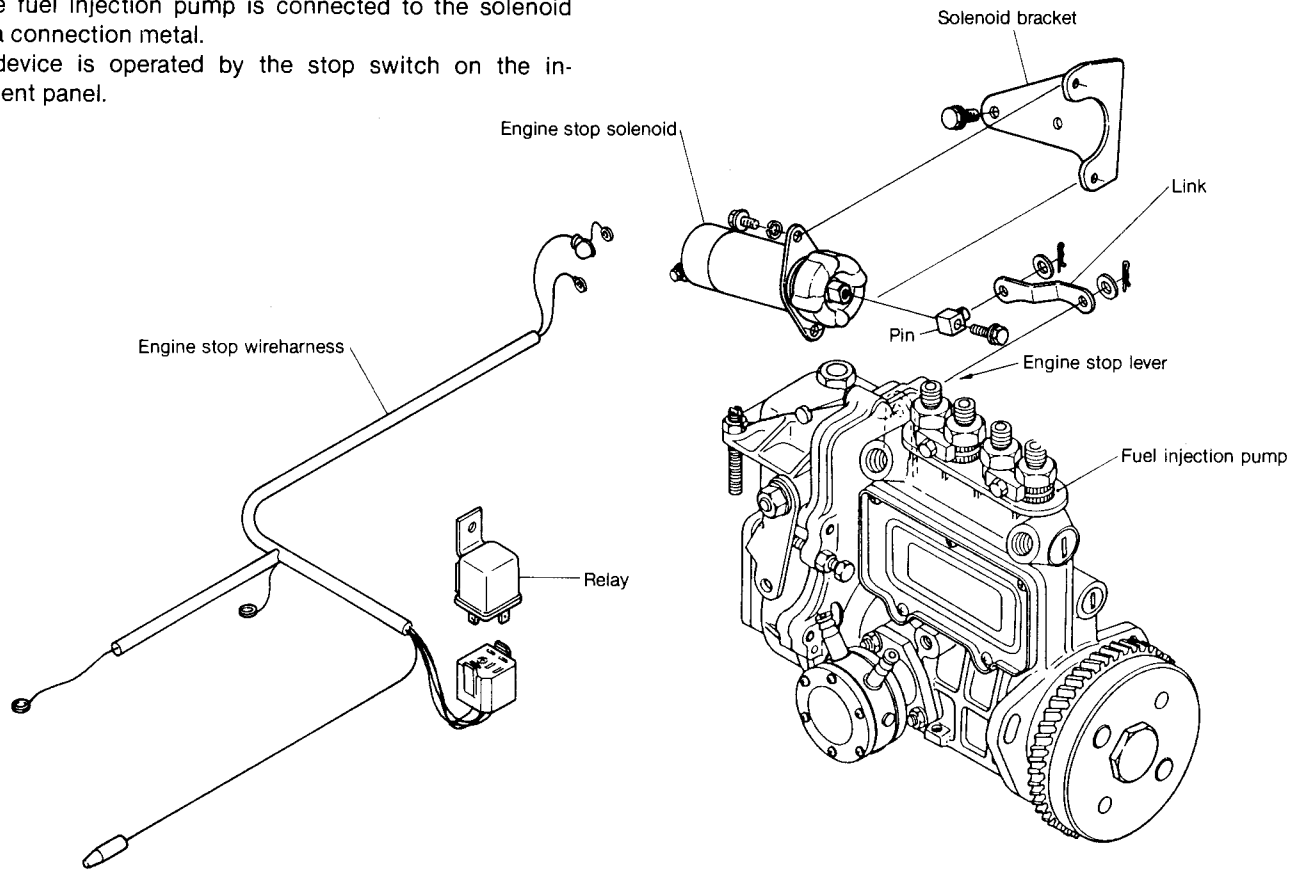

8-1 Solenoid

Solenoid model	1502-12A7U1B
Rated voltage	12V
Loaded current	30A
Loaded force	9kg (19.84lb)
No-load current	0.7A
No-load force	4kg (8.82lb)

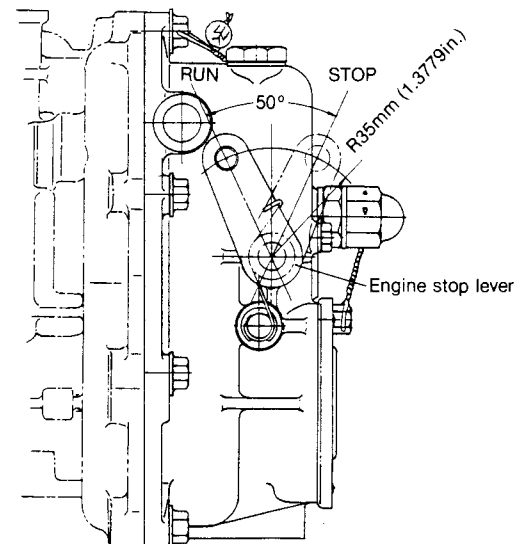
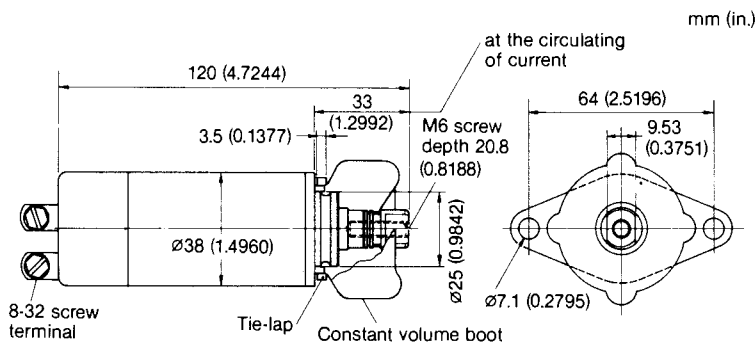

8-2 Relay

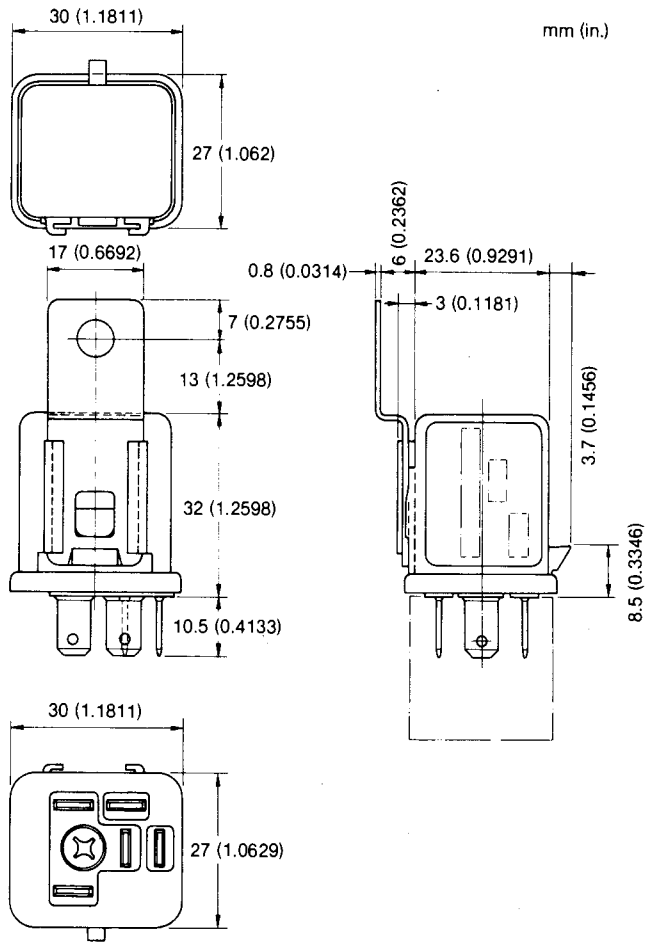

Rated voltage	12V
Contact current	Lamp: 20A, extra-lamp: 25A
Range of operation	-30°C ~ +90°C (-22°F ~ 194°F)
Part code No.	124617-91850

8-3 Wire harness of engine stop

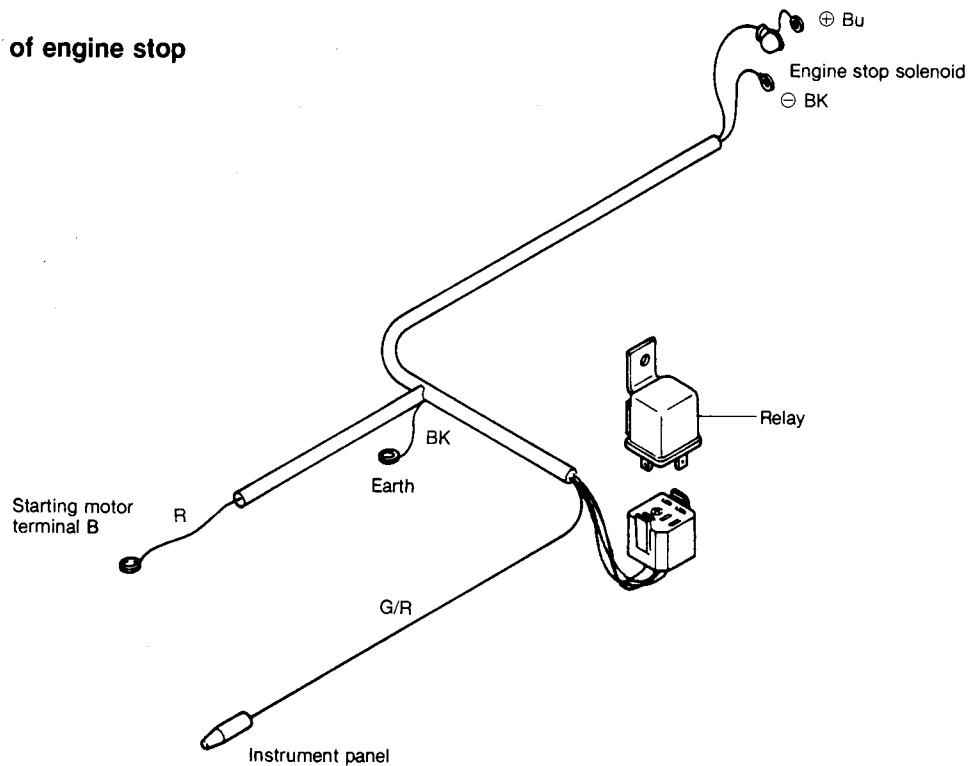

9. Tachometer

9-1 Construction of tachometer

The tachometer indicates the number of revolutions per minute by means of an electrical input signal which is generated as a pulse signal from the magnetic pickup sender (MPU sender).

The function of the sender is to convert the rotary motion into an electrical signal by means of counting the number of teeth of the ring gear connecting with the flywheel housing.

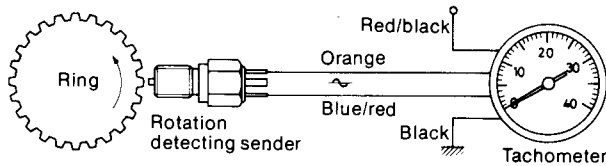
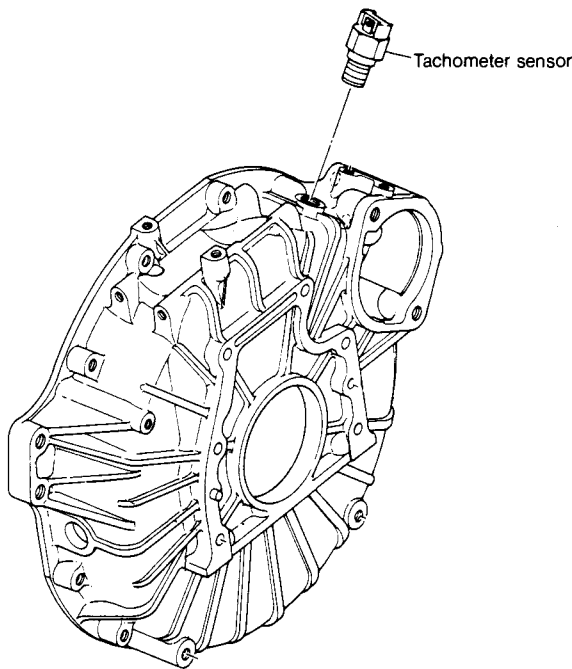

(2) Sensitivity limit of sender unit

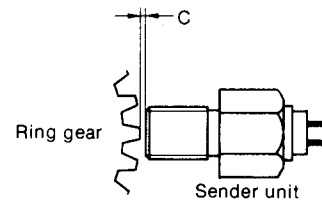
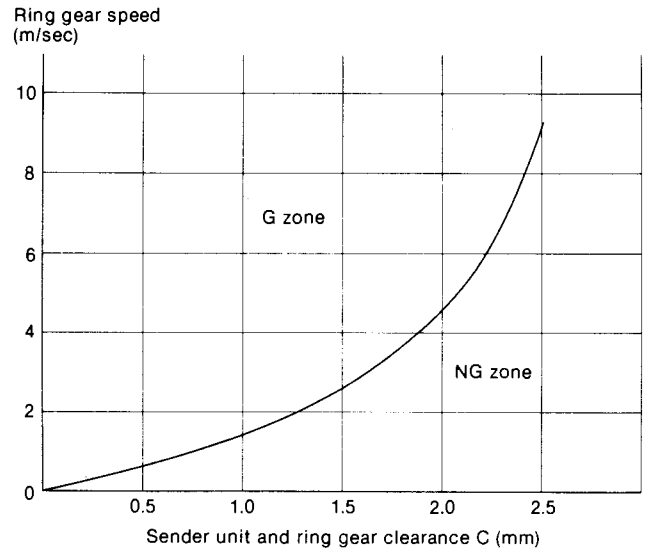

(3) Dimensions of sender unit

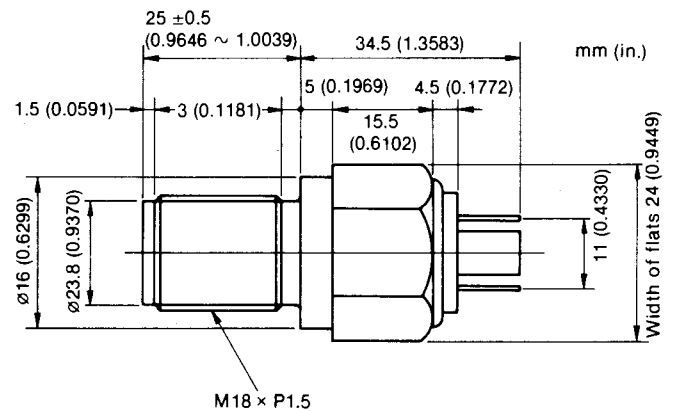

(4) Dimensions and shape of tachometer

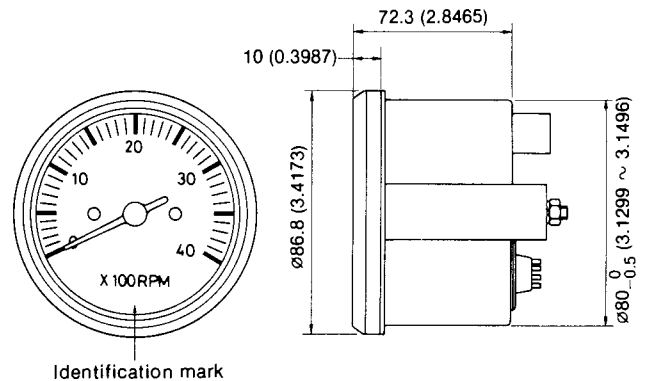

9-2 Specifications and dimensions of tachometer

(1) Specifications

Rated voltage	DC 12V
Range of operating voltage	10 ~ 15V
Illumination	3.4W/12V
Ring gear	No. of teeth 127 Module 2.54
Part No. of tachometer	120130-91200 (128696-91100)
Part No. of sender unit	128170-91160

9-3 Measurement of sensor unit characteristics

(1) Measurement of output voltage

Output voltage	1.0V or higher
----------------	----------------

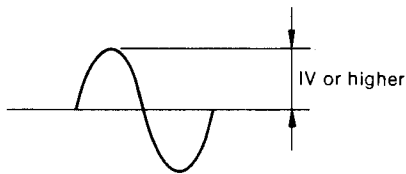

Measuring conditions

Number of teeth of ring gear	127
Gap between the ring gear and sender	1.3mm (0.0511 in.)
Resistance	20kΩ
Speed of ring gear	500 rpm (approx. 800Hz)
Measuring temperature	20°C (68°F)
Measuring instrument	Synchroscope

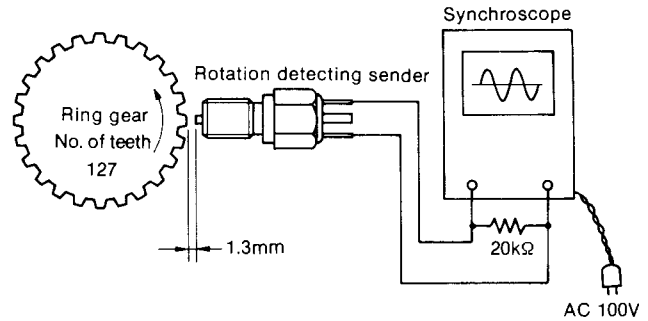

* Check the output wave pattern and number of pulses when carrying out the output voltage measurement.

(2) Measurement of internal resistance

Measuring conditions

Measuring temperature	20°C (68°F)
Measuring instrument	Digital tester

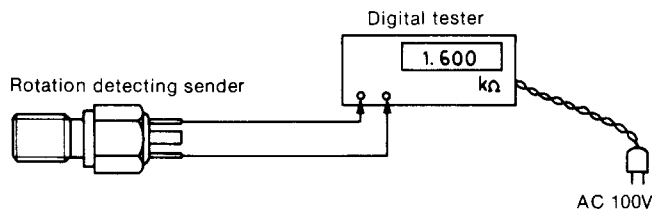

9-4

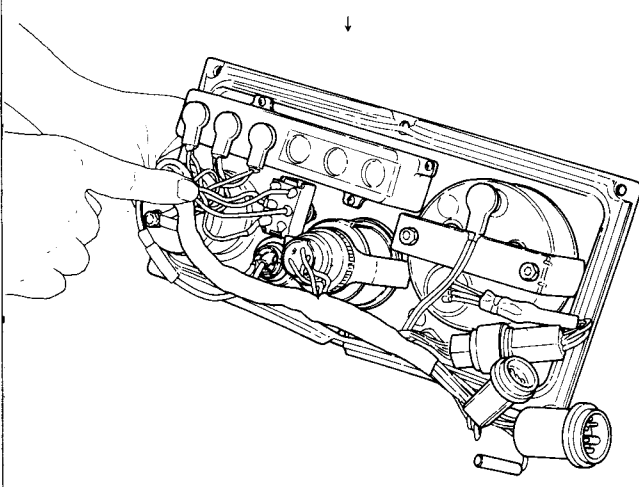
Fault	Diagnosis	Remedy
Does not function well. 1) Pointer does not move. 2) Functions intermittently.	Check if there is an open-circuit cable connection at the rear of the meter, a loose or disconnected terminal, or bad continuity due to corrosion. ↓ 	Yes Make good the connection.
	Disconnect at the instrument terminals, and measure the voltage between the cable terminals. (To be 10 ~ 16V) ↓ Satisfactory	No If the input voltage is abnormal, check the cause. (e.g. short-circuit, disconnection, or blown fuse, etc.)

	Check if the sender is loosely fitted. ↓ No	Yes Fix the sender securely.
	Measure the internal resistance of the sender. (To be $1.6 \pm 0.1k\Omega$ at 20°C) ↓	No Replace the sender.
	Measure the output voltage of the sender. (To be 1V or higher at 20°C)	No Replace the sender.

10. Alternator 12V/80A (OPTIONAL)

The alternator serves to keep the battery constantly charged. It is installed on the cylinder block by a bracket, and is driven from the V-pulley at the end of the crankshaft by a V-belt.

The type of alternator used in this engine is ideal for high speed engines with a wide range of engine speeds. It contains diodes that convert AC to DC, and an IC regulator that keeps the generated voltage constant even when the engine speed changes.

10-1 Features

The alternator contains a regulator using an IC, and has the following features.

- (1) The IC regulator is self-contained, and has no moving parts (mechanical contact points). It therefore has superior features such as freedom from vibration, no fluctuation of voltage during use, and no need for readjustment. Also, it is of the over-heating compensation type and can automatically adjust the voltage to the most suitable level depending on the operating temperature.
- (2) The regulator is integrated within the alternator to simplify external wiring.
- (3) It is an alternator designed for compactness, lightness of weight, and high output.
- (4) A newly developed U-shaped diode is used to provide increased reliability and easier checking and maintenance.
- (5) As the alternator is to be installed on board, the following measures are taken to provide salt-proofing.
 - 1) The front and rear covers are salt-proofed.
 - 2) Salt-proof paint is applied to the diode.
 - 3) The terminal, where the inboard harness is connected to the alternator, is nickel plated.

10-2 Specifications

Model of alternator	LR180-03 (HITACHI)
Model of IC regulator	TRIZ-63 (HITACHI)
Battery voltage	12V
Nominal output	12V/80A
Earth polarity	Negative earth (⊖)
Direction of rotation (viewed from pulley end)	Clockwise
Weight	5.8kg (12.8lb.)
Rated speed	5000 rpm
Operating speed	1000 ~ 9000
Speed for 13.5V	1000 or less
Output current at 20°C	over 78A/5000 rpm
Regulated voltage	14.5 ±0.3V (Standard temperature voltage gradient, -0.01/°C)

10-3 Characteristics

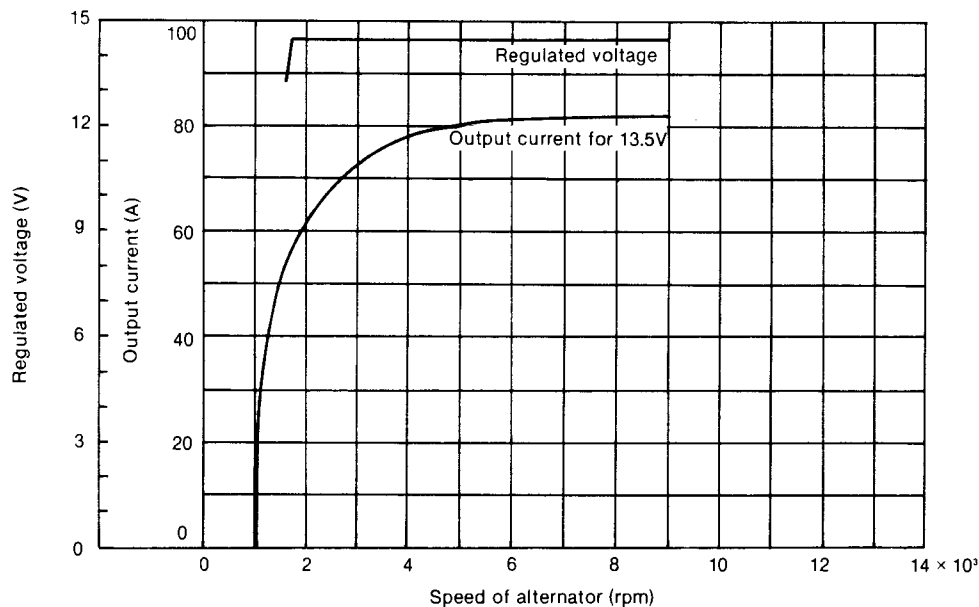

10-4 Construction

This is a standard rotating field type three-phase alternator. It consists of six major parts: the pulley, fan, front cover, rotor, stator and rear cover. The IC regulator is an integral part of the alternator.

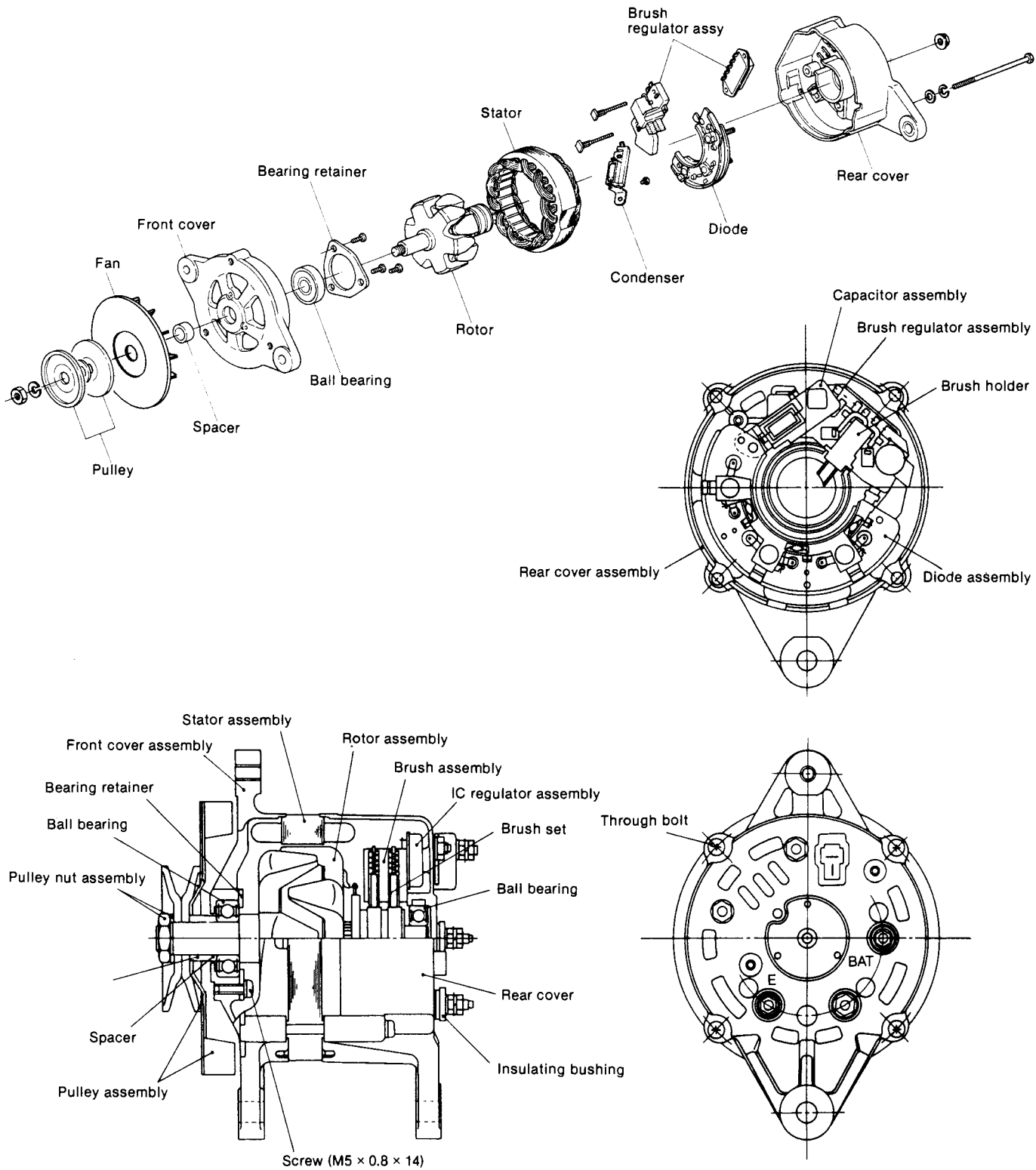

10-5 Alternator functioning

(1) IC regulator

The IC regulator is the transistor (Tr_1) which is series-connected with the rotor. The IC regulator controls the output voltage of the generator by breaking or conducting the rotor coil (exciting) current.

When the output voltage of the generator is within the standard value, the transistor (Tr_1) turns on. When the voltage exceeds the standard value, the Zener diode goes on and the transistor (Tr_1) turns off.

With the repeated turning on and off of the transistor, the output voltage is kept at the standard value. (Refer to the circuit diagram below.)

(2) Charge lamp

When the transistor (Tr_1) is on, the charge lamp key switch is turned to ON, and current flows to R_1 , R_4 and to Tr_1 to light the lamp. When the engine starts to run and output voltage is generated in the stator coil, the current stops flowing to this circuit, turning off the charge lamp.

(3) Circuit diagram

10-6 Handling precautions

(1) Be careful of the battery's polarity (+, - terminals), and do not connect the wrong terminals to the wrong cables, or the battery will be short-circuited by the generator diode.

In this case too much current will flow, the IC regulator and diodes burn out, and the wire harness will burn.

(2) Make sure of the correct connection of each terminal.

(3) When quick-charging, etc., disconnect either the battery terminal on the AC generator or the terminal on the battery.

(4) Do not short-circuit the terminals.

(5) Do not conduct any tests using high tension insulation resistance. (The diodes and IC regulator will burn out.)

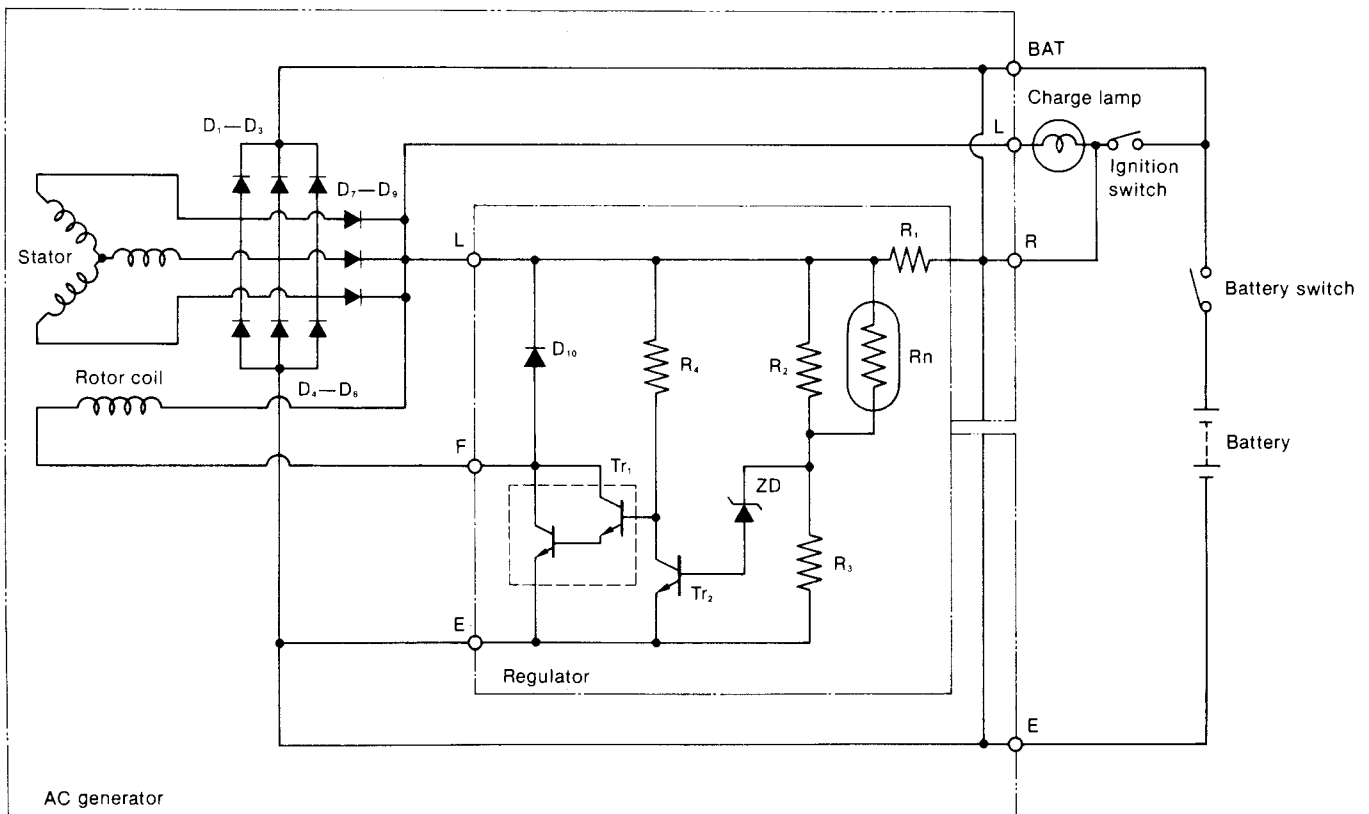

- | | | | |
|-------------------------------------|---------------------------|----------------------------------|--|
| BAT: | Generator output terminal | D ₁ -D ₆ : | Output commutation diode |
| D ₁₀ : | IC protecting diode | R ₁ -R ₄ : | Resistor |
| L: | Charge lamp terminal | D ₇ -D ₈ : | Charging lamp switching diode |
| ZD: | Zener diode | F: | To supply current to rotor coil |
| E: | Earth | R _n : | Thermistor (Temperature gradient resistance) |
| Tr ₁ , Tr ₂ : | Transistor | | |

10-7 Disassembling the alternator

(1) Remove the through-bolt, and separate the front assembly from the rear assembly.

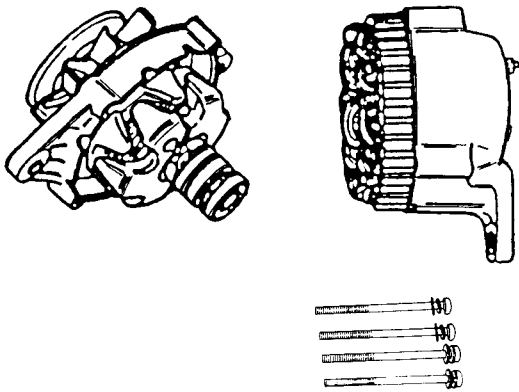

(2) Remove the pulley nut, and pull out the rotor from the front cover.

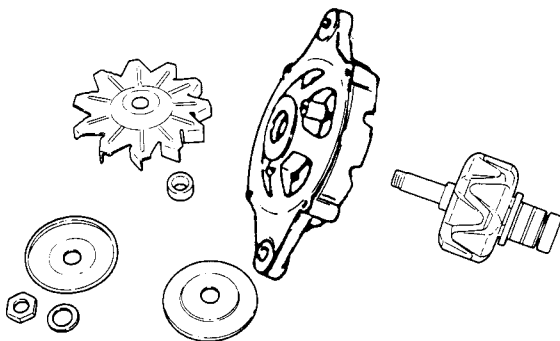

(3) Remove the $\varnothing 5\text{mm}$ ($\varnothing 0.1969\text{in.}$) screw from the front cover, and then remove the ball bearing.

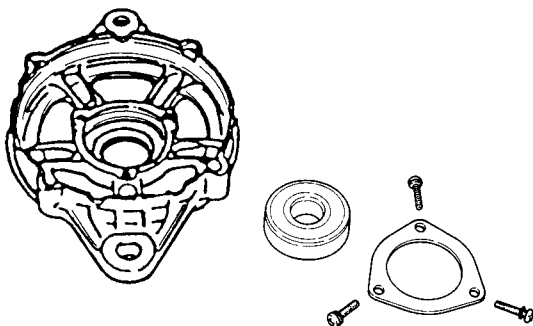

(4) Remove the nut, the brush-holder, and diode fixing nut at the BAT, and the terminal screws of the rear cover. Separate the rear cover from the stator (with the diode and brush holder).

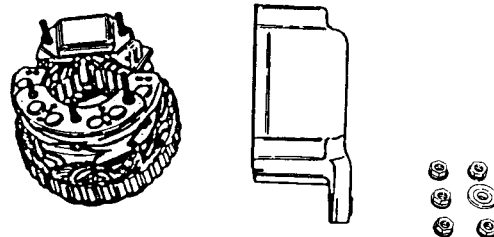

(5) Disconnect the soldered joint of the stator lead wire, and remove the diode and brush regulator assemblies from the stator at the same time.

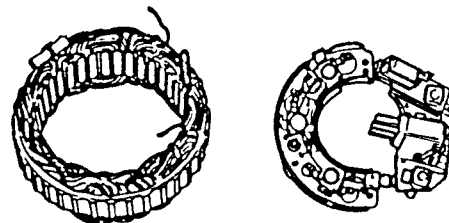

(6) Separating the regulator

1) To separate the regulator, remove the $\varnothing 3\text{mm}$ ($\varnothing 0.1181\text{in.}$) rivet which keeps the diode assembly and the brushless regulator in place, and the soldered joint of the L-terminal.

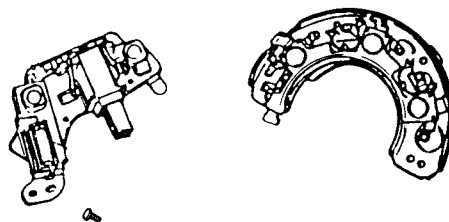

2) To replace the IC regulator, disconnect the soldered joint of the IC regulator and pull out the two bolts. Do not remove these two bolts except when replacing the IC regulator.

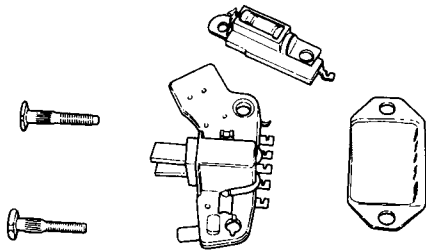

After repeating the above test, if any diode is found to be defective, replace the diode assembly. Since there is no terminal on the auxiliary diode, check the continuity between both ends of the diode.

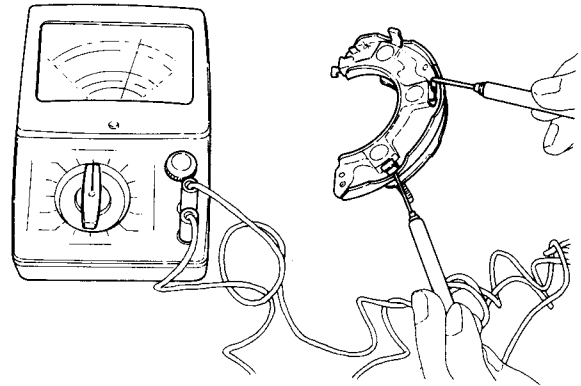

10-8 Inspection and adjustment

(1) Diode

Between terminals		BAT (+ side diode)	
	Tester wire	+ side	- side
U.V.W.	+ side	No continuity	
	- side		

Between terminals		E (- side diode)	
	Tester wire	+ side	- side
U.V.W.	+ side	Continuity	
	- side		

CAUTION: Do not use high tensile insulation resistance such as meggers, etc. for testing. The diode may burn out.

(2) Rotor

Inspect the slip ring surface, rotor coil continuity and insulation.

1) Inspecting the slip ring surface

Check if the surface of the slip ring is sufficiently smooth. If the surface is rough, grind the surface with No. 500—600 sand paper. If it is contaminated with oil, etc., wipe the surface clean with alcohol.

Slip ring outer dia.	Standard	Wear limit
	ø31.6mm (1.2441in.)	ø30.6mm (1.2049in.)

2) Rotor coil continuity test

Check the continuity in the slip ring with the tester. If there is no continuity, there is a wire break. Replace the rotor coil.

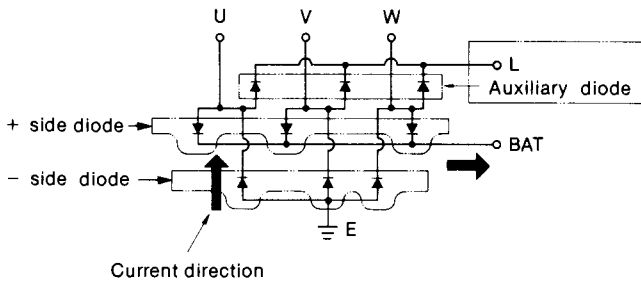

U.V.W.: terminal from the stator coil

Current flows only in one direction in the diode as shown in Fig. 181. Accordingly, when there is continuity between each terminal (e.g. BAT and U), the diode is in normal condition. When there is no continuity, the diode is defective.

When the tester is connected in the reverse of above, there should be no continuity. If there is, the diode is defective.

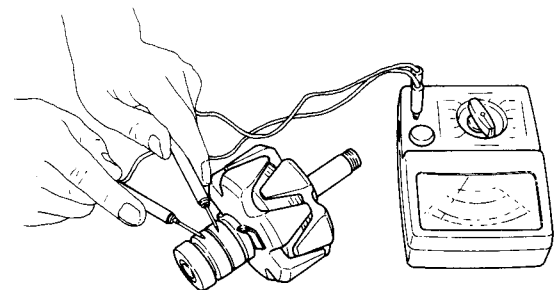

Resistance value	Approx. 2.58Ω at 20°C
------------------	-----------------------

3) Rotor coil insulation test

Check the continuity between the slip ring and the rotor core, or the shaft. If there is continuity, insulation inside the rotor is defective, causing a short with the earth circuit. Replace the rotor coil.

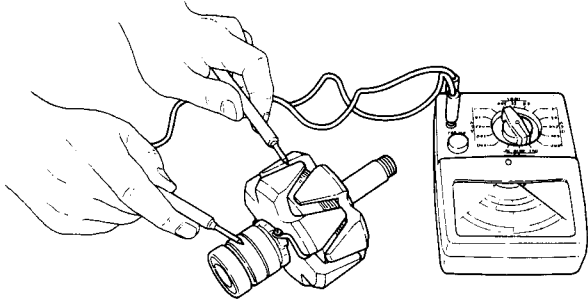

2) Stator coil insulation test

Check the continuity between the terminals and the stator core. If there is continuity, insulation of the stator coil is defective. This will cause a short-circuit with the earth core. Replace the stator coil.

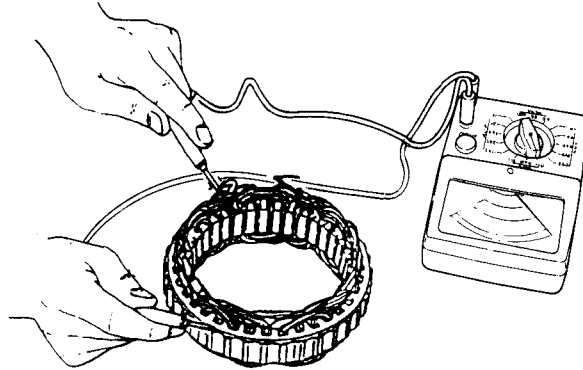

4) Check the rear side ball bearing. If the rotation of the bearing is heavy, or produces abnormal sounds, replace the ball bearing.

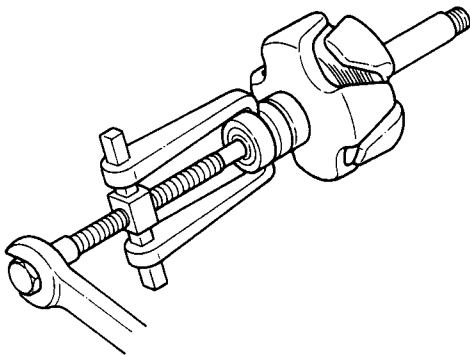

(4) Brush

The brush is hard and wears slowly, but when it is worn beyond the allowable limit, replace it. When replacing the brush, also check the strength of the brush spring. To check, push the spring down to 2mm (0.0787in.) from the end surface of the brush holder, and read the gauge.

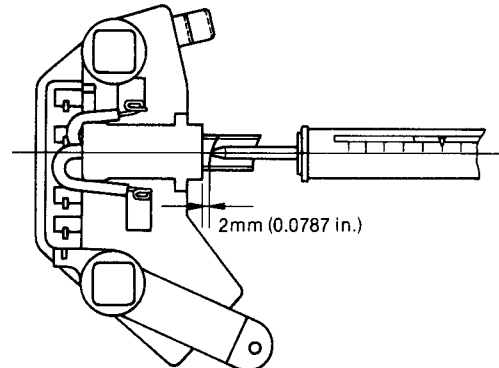

Brush spring strength	255—345g (0.56 ~ 0.76lb.)
-----------------------	---------------------------

(3) Stator

1) Stator coil continuity test

Check the continuity between each terminal of the stator coil. If there is no continuity, there is a wire break in the stator coil. Replace the stator coil.

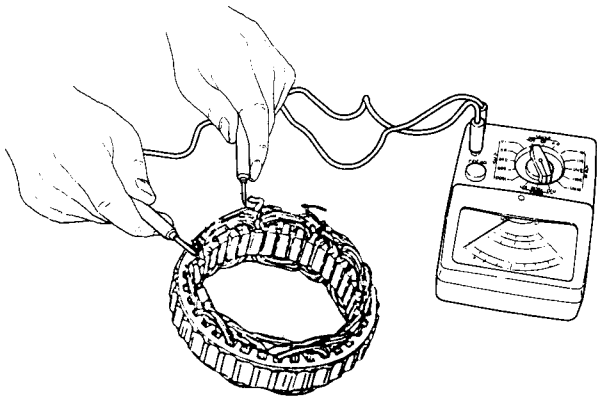

(5) Brush wear

Check the brush length. The brush wears very little, but replace the brush if worn over the wear limit line printed on the brush.

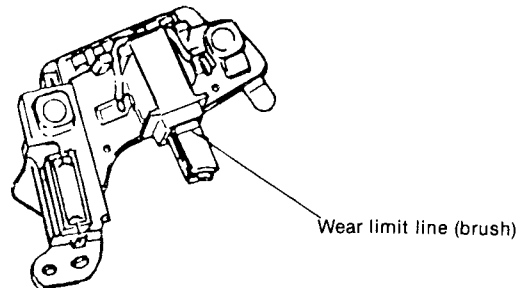

Resistance value	Approx. 0.041Ω at 20° C u, v-phase resistance
	Approx. 0.036Ω at 20° C w-phase resistance

	mm (in.)	
Brush length	Maintenance standard 16 (0.6299)	Wear limit 9 (0.3543)

(6) IC regulator

Connect the variable resistance, two 12V batteries, resistor, and voltmeter as shown in the diagram.

1) Use the following measuring devices.

- Resistor (R₁) 100Ω, 2W, 1pc.
- Variable resistor (R_v) 0—300Ω, 12W, 1pc.
- Battery (BAT₁, BAT₂) 12V, 2pcs.
- DC voltmeter 0—30V, 0.5 class 1pc.
(measure at 3 points)

2) Check the regulator in the following sequence, according to the diagram.

- a) Check V₃ (BAT₁ + BAT₂ voltage). If the voltage is 20—26V, both BAT₁ and BAT₂ are normal.
- b) While measuring V₂ (F-E terminal voltage), move R_v gradually from the 0-position. Check if there is a point where the V₂ voltage rises sharply from below 2.0V to over 2.0V. If there is no such point, the regulator is defective. Replace the regulator. If there is a sharp voltage rise when testing, return the R_v to the 0-position, and connect the voltmeter to the V₁ position.
- c) While measuring V₁ (voltage between L-E terminals), move R_v gradually from the 0-position. There should be a point where the voltage of V₁ rises sharply by 2—6V. Measure the voltage of V₁ just before this sharp voltage rise. This is the regulating voltage of the regulator. If this voltage of V₁ is within the standard limit, the regulator is normal. If the voltage deviates from the limit, the regulator is defective. Replace the regulator.

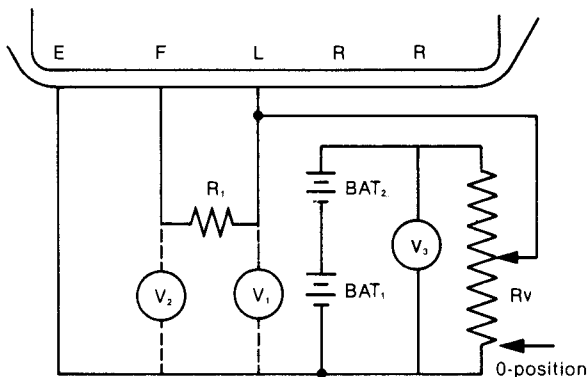

10-9 Reassembling the alternator

Reassembly is done in the reverse order of disassembly. For reassembly, be careful of the following points. (Refer to 4—7 disassembling alternator).

(1) Assembling the brush regulator

1) Solder the brush.

Position the brush as shown in the drawing and solder it. Be careful not to let the solder drip into the pig tail (lead wire).

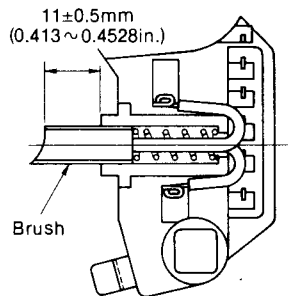

Wind the wire 1.5 times around the terminal groove.

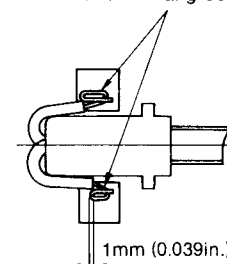

Mount the insulation tube on the terminal surface.

NOTES: 1. Use non-acid type paste.

2. The soldering iron temperature is 300 ~ 350°C.

2) Mount the IC regulator on the brush holder as illustrated, and press in the M5 bolt. Do not forget to assemble the bushing and the connecting plate at the same time.

(If the bushing is left out, the output terminal will be earthed and the battery short-circuited).

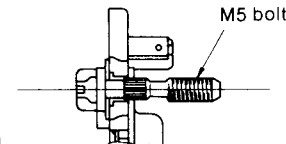
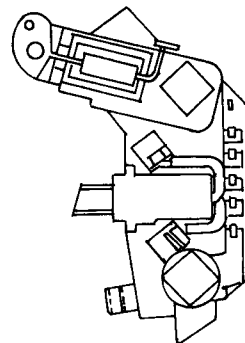

NOTES: 1. Insertion pressure is 100kg (220.5 lbs.)

2. Insert vertically.

(2) Connecting the brush regulator assembly and diode

1) Check the rivets

Place the rivets as shown in the figure, and then calk them using the calking tool.

Calking torque	500kg (1102 lbs.)
----------------	-------------------

2) Connect the brush to the diode.

Insert the brush side terminal into the diode terminal, calk it, and then solder into place.

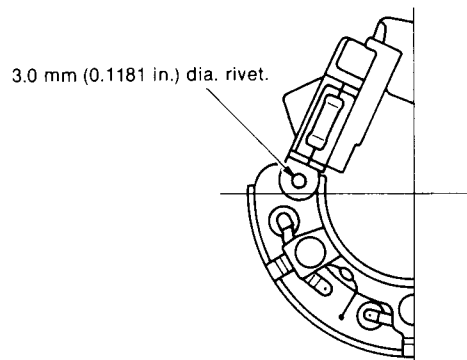

Rivetting pressure	500kg (1102 lbs.)
--------------------	-------------------

(3) Assembling the rear cover

Insert pins from the outside of the rear cover. Install the brush on the brush holder, then attach the rear cover. After assembly, pull out the pins.

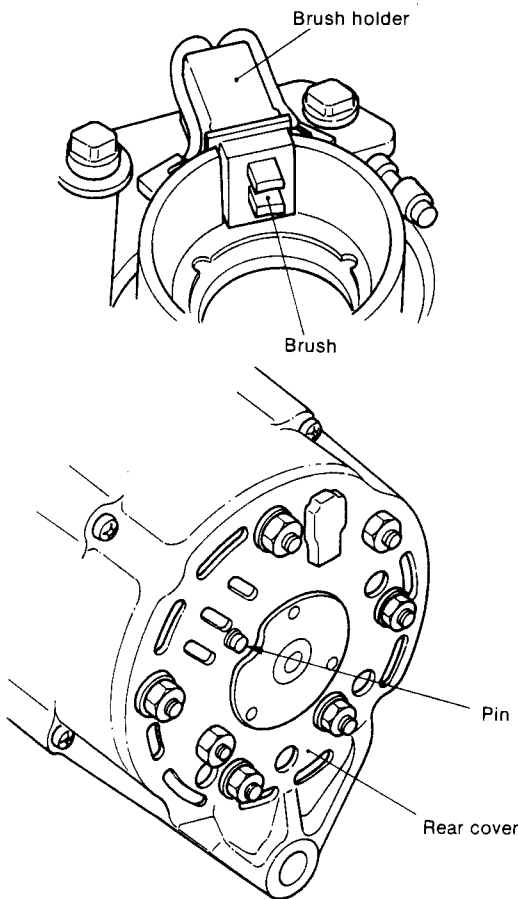

(1) Measuring devices

DC voltmeter	0—15V or 0—30V, 0.5 Class, 1pc.
DC ammeter	0—100A, 1.0 Class, 1pc.
Variable resistor	0—0.25Ω, 1kW, 1pc.
Lamp	12V, 3W
100Ω resistor	3W
0.25Ω resistor	25W

(2) Measuring the regulating voltage

- 1) When measuring devices are connected in the performance test circuit as shown above, the charge lamp lights.
- 2) Close SW₂ while keeping SW₁ open and run the AC generator. When the revolutions of the generator are gradually raised, the charge lamp goes off.
- 3) Raise the revolutions of the AC generator, and read the voltmeter gauge when the revolutions reach about 5,000 rpm.

NOTES: 1. Make sure that the ammeter indication at this time is less than 5A. If the indication is over 5A, connect the 0.25Ω resistor. The voltmeter indication at this time must be within the prescribed regulating voltage value.

2. Raise the AC generator revolutions high to make sure the regulating voltage does not fluctuate along with changes in the revolution speed.

(3) Precautions for measuring the regulating voltage

- 1) When measuring the voltage, measure the voltage between the AC generator BAT terminal, or Battery + terminal, and AC generator E-terminal.
- 2) Use a fully charged battery.
- 3) Measure the voltage quickly.
- 4) Keep SW₁ open for measurement.

(4) Tightening torques

Positions	Tightening torque kg-cm (ft-lb)
Brush holder fixing	32—40 (2.31~2.89)
Diode fixing	60—70 (4.33~5.05)
Bearing retainer fixing	32—40 (2.31~2.89)
Pulley nut tightening	400—600 (28.93~43.40)
Through-bolt tightening	32—40 (2.31~2.89)

10-10 Performance test

Conduct a performance test on the reassembled AC generator as follows. The following is the circuit for the performance test.

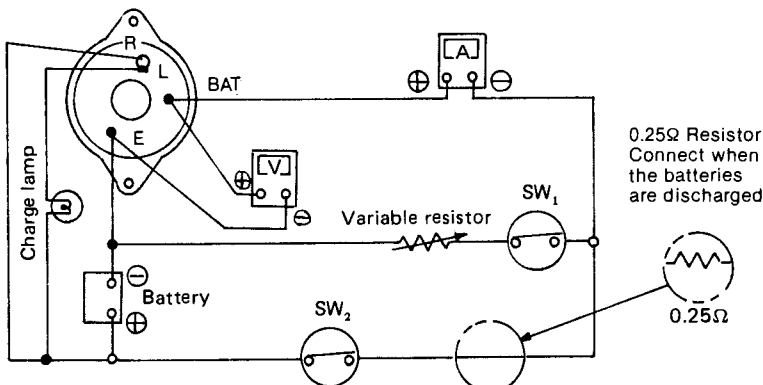

10-11 Troubleshooting

(1) Charging failure

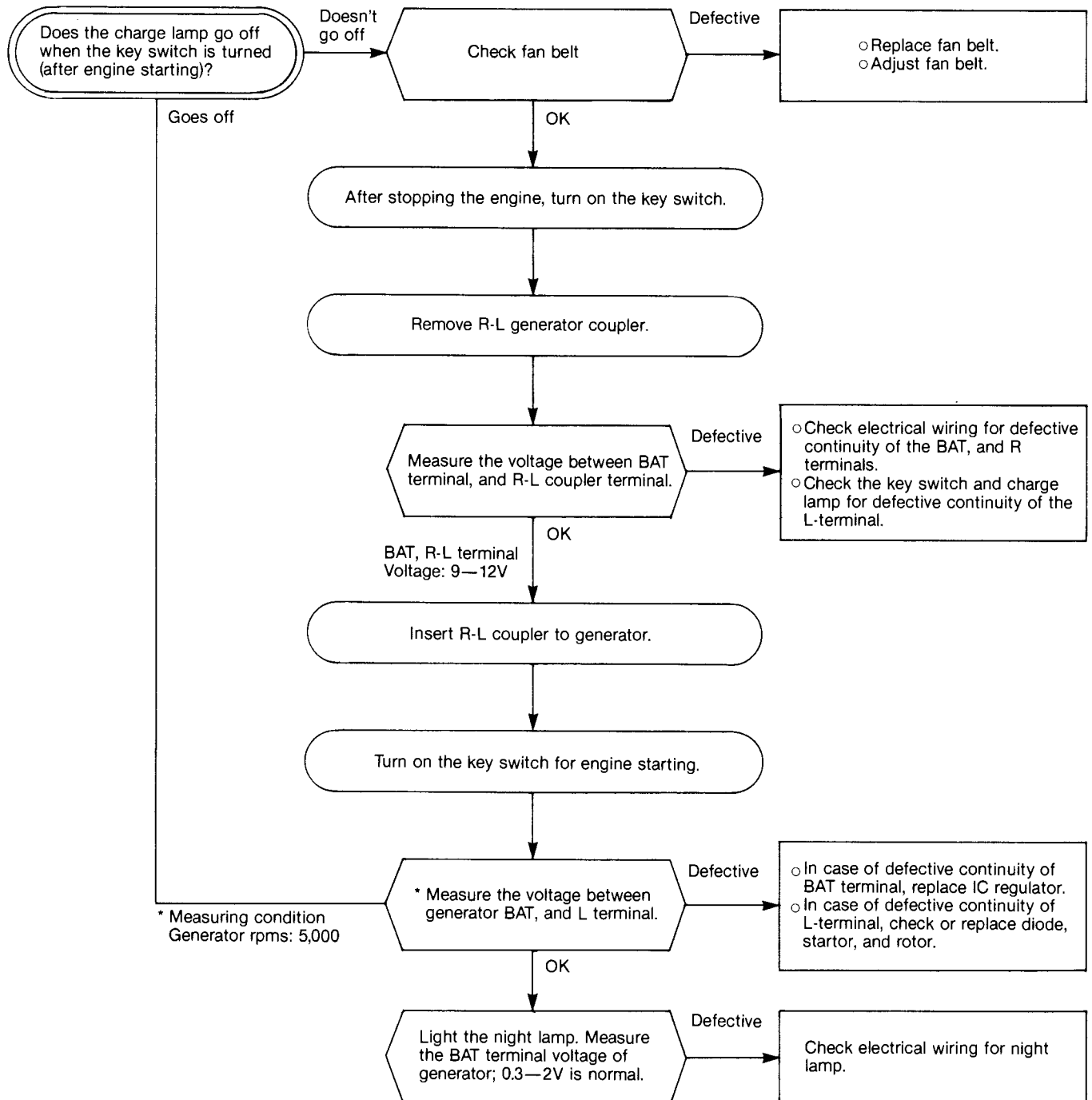

(2) Overcharging

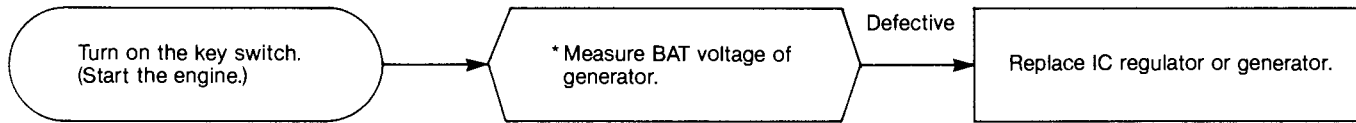

(3) Charge lamp failure

